

OFF-THE-ROAD

**PRODUCT
DATA BOOK**

FIRESTONE VERSION 2022



FIRESTONE REFERENCE INFORMATION

TIRE ABBREVIATIONS

	DESCRIPTION
CRC	Cut Resistant Compound / Construction (Type 2-A)
TC	Transport Compound
NY	Nylon
NS	Nylon Steel [Nylon Casing with Steel Breaker Belts]
LD	Loader Dozer
NHS	Non-Highway Service
UMS	Underground Mining Service
IDU	Industrial
MH	Material Handler

	DESCRIPTION
E-2	Earthmover Traction Regular Tread
E-3	Earthmover Rock Regular Tread
E-4	Earthmover Rock Deep Tread
E-7	Earthmover Flotation Tread
L-2	Loader Traction Regular Tread
L-3	Loader Rock Regular Tread
L-3S	Loader Smooth Regular Tread
L-4	Loader Rock Deep Tread
L-4S	Loader Smooth Deep Tread
L-5	Loader Rock Extra Deep Tread
L-5S	Loader Smooth Extra Deep Tread
L-5/L-5S	Loader Rock Extra Deep/Smooth Extra Deep Tread
G-2	Grader Traction Regular Tread
G-4	Grader Rock Deep Tread
IND-3	Industrial Regular Tread
IND-3S	Industrial Smooth Regular Tread
IND-4	Industrial Deep Tread
IND-4S	Industrial Smooth Deep Tread
IND-5	Industrial Extra Deep Tread
IND-5S	Industrial Smooth Extra Deep Tread

For the TKPH (TMPH) ratings of bias tires, consult Firestone representative.

For the Load and Inflation Pressure tables, refer to the following notes.

1. Maximum speeds => Earthmover Service: 50km/h (30mph), Grader Service: 40km/h (25mph), Loader & Dozer Service: 10km/h (5mph), Compactor Service: 10km/h (5mph)
2. Figures under the ply rating denote the maximum load and inflation pressure.
3. For Loader & Dozer service, Dig & Load operation or distances are up to 76m (250ft) one way.

For Off-The-Road Tires used For Industrial vehicle applications, refer to following notes.

1. Industrial vehicles comprise of vehicles such as counter-balanced lift trucks, container handlers, straddle carriers, aircraft tow tractors, mobile crushers, log stackers, etc., used on hard improved surfaces, smooth floors and runways.
2. Consult a rim manufacturer when inflation pressure exceeds 800 kPa (116 psi).
3. For speeds exceeding 30 km/h (18 mph), consult a Firestone representative.
4. For tire sizes or ply ratings other than listed above, consult a Firestone representative.
5. For RTG (Rubber Tired Gantry crane) operation, consult a Firestone representative.

TABLE OF CONTENTS

INTRODUCTION

Industry Standard	4
Application Vehicle Matching Chart.....	4

GENERAL INFORMATION

Structural Diagram	5
Definitions.....	6
Classification	7
Tire Markings	9

RADIAL TIRES

24" / 25"	15
25"	16

BIAS TIRES

24"	20
24" / 25"	21
25"	22
28"	29
29"	30
33"	31
33" / 35"	34
35"	35
35" / 39"	36
39"	37
45"	38
49"	39
51"	40
56.5" / 57"	41
57"	42

COMPACT RADIAL TIRES

18"	44
24"	46

COMPACT BIAS TIRES

15"	48
16"	49
16.1" / 16.5"	50
16.5" / 17.5"	51
18" / 19.5"	52
19.5"	53
22.5"	55
24"	56
24" / 28"	57
28"	58

REMARKS & SPECIAL OPERATIONS

Remarks.....	59
Special Operations	61

INTRODUCTION

1. Industry Standard

Firestone has developed a wide range of tire patterns and specifications, so that the proper Off-the-Road tire can be matched to any vehicle, service, or operating conditions.

Firestone's Off-the-Road tires are designed and produced to meet the commonly accepted international standards, those set by the TRA (Tire and Rim Association) in the U.S.A., by the ETRTO (European Tire and Rim Technical Organization) in Europe and/or by the JATMA (Japan Automobile Tire Manufacturers' Association) in Japan*.

Load capacities, inflation pressures, dimensions such as overall tire diameter and width, as well as the relative rims and tube valves follow these standards.

If a tire is to be used for a purpose other than that for which it is originally intended, please consult Firestone Corporation for advice.

*Where differences exist between the TRA, ETRTO and JATMA standards, Firestone selects the most applicable.

2. Application Vehicle Matching Chart

APPLICATION	VEHICLE
Earthmover Service	Dump Trucks, Motor Scrapers, Articulated Dump Trucks, Coal Haulers, Logging Trucks, Other Mining Trucks, etc.
Grader Service	Motor Graders
Loader & Dozer Service	Front-End Loaders, Back-hoe Loaders, Skid Steer Loaders, Dozers, Underground Trucks, Load-Haul-Dumps, etc.
Mobile Crane Service (High-Speed)	All-Terrain Cranes, High-Speed Vehicles, etc.
Industrial Service	Straddle Carriers, Aircraft Towing Tractors, Container Stackers, Counter-balanced Lift Trucks, Mobile Crushers, Log Stackers, etc.
Logging Service	Log-Skidders
Compactor Service	Compactor, Road Rollers
Sand Service	Sand Service Trucks
Underground Service	Underground Trucks, Load Haul Dumps, Drilling Jumbo

GENERAL INFORMATION

1. Structural Diagram

Off-The-Road Radial Tire (ORR)

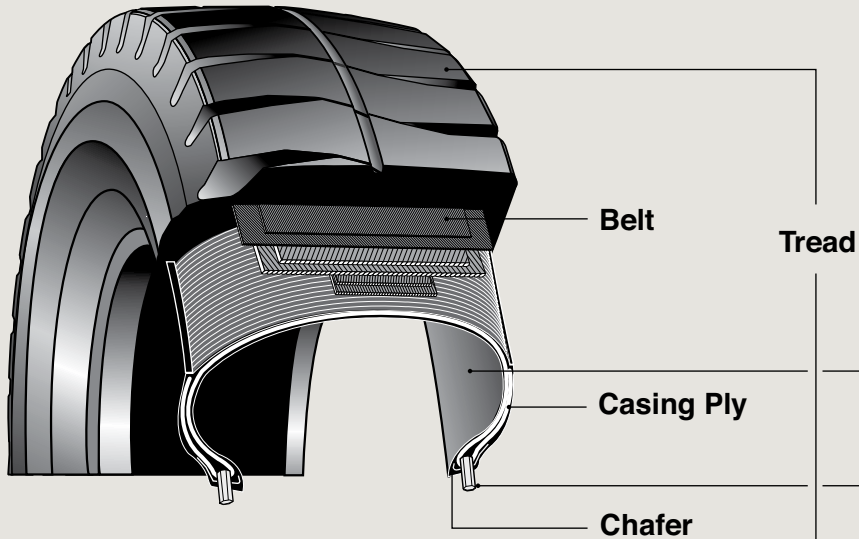

Off-The-Road Bias Tire (ORS)

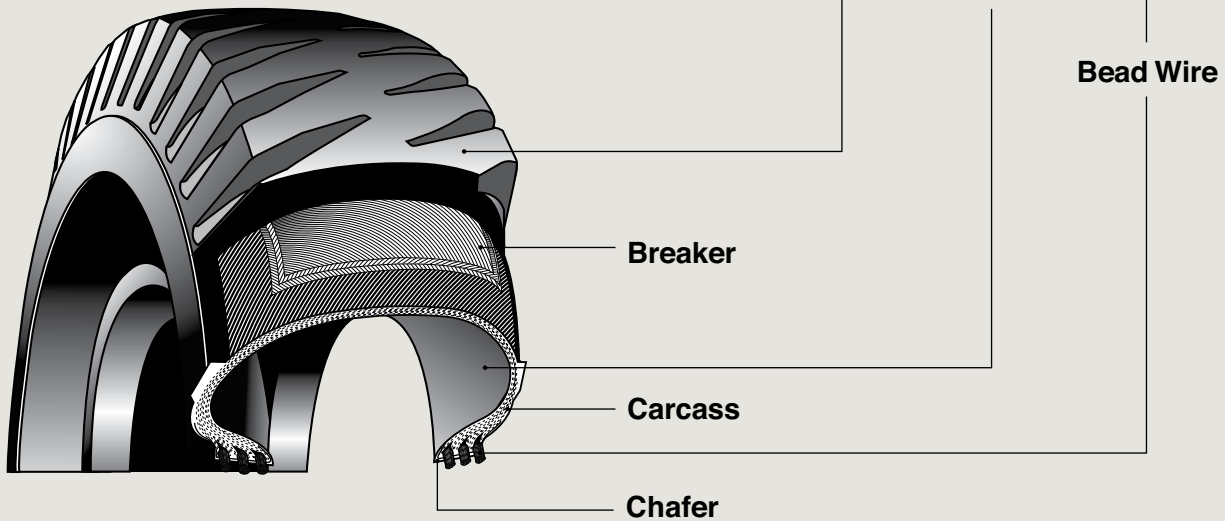

2. Definitions

2.1 Tire Size

The size of each tire is indicated by nominal width and rim diameter in inches and mm.

Radial structure is indicated by the letter "R". For some tire the aspect ratio is indicated by percentage.

Example

Radial Tire ; 40.00R57, 33.25R35, 445/95R25 Bias Tire ;
21.00-35, 45/65-45

2.2 Star Rating, Ply Rating and Load Index

The load capacity of a tire is indicated by the star rating (in case of radial tire) and the ply rating (in case of bias tire).

The load index is applied in countries where the ETRTO standards are used.

2.3 Overall Diameter (OD)

"Overall Diameter" is twice the section height of a new tire, plus the nominal rim diameter, including 24-hour inflation growth.

2.4 Overall Width (OW)

"Overall Width" is the width of a new tire, including 24- hour inflation growth, and including protective side ribs, bars or decorations.

2.5 Section Width (SW)

"Section Width" is the width of a new tire, including 24- hour inflation growth and including normal sidewalls, but not including protective side ribs, bars, or decorations.

2.6 Static Loaded Radius and Width (SLR, SLW)

"Static Loaded Radius" is the shortest distance from the axle center to the contact surface of a tire and "Static Loaded Width" is the overall width of a tire, mounted on the approved rim at the specified inflation pressure and placed still and vertically on a flat board, and loaded with the specified load.

2.7 Original Tread Depth (OTD)



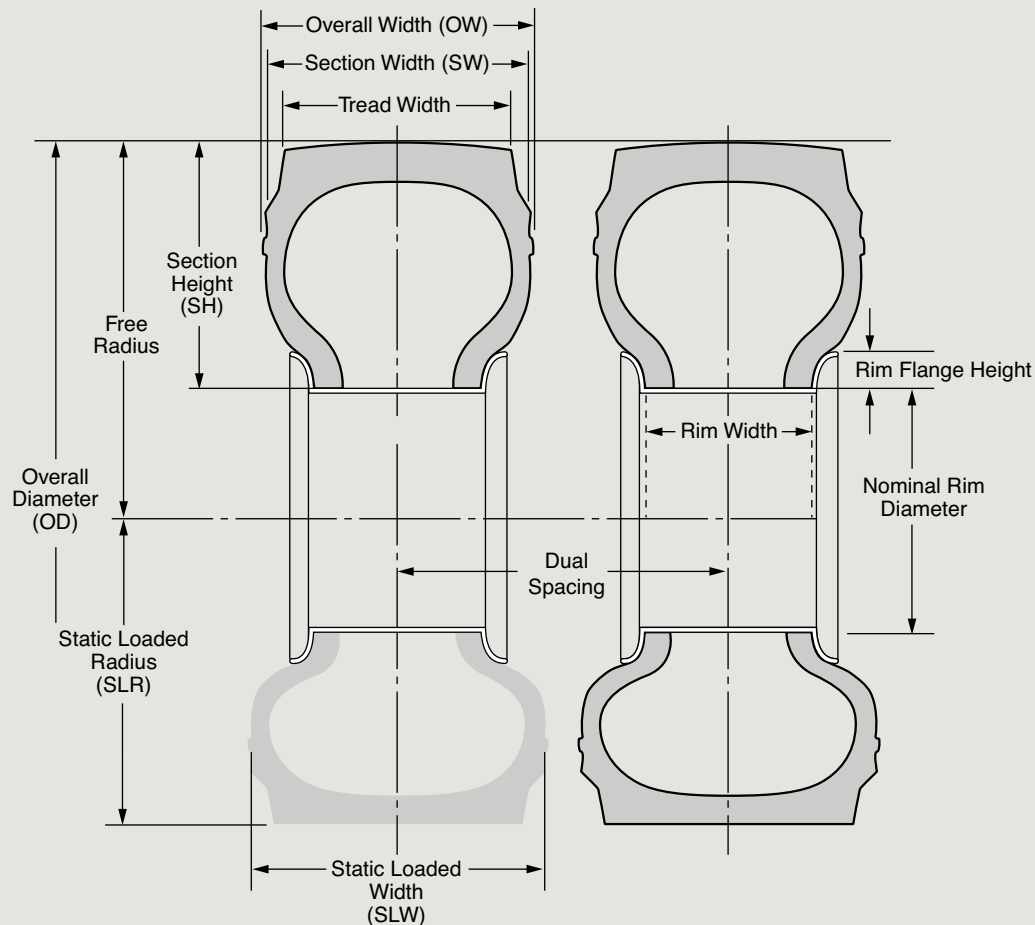











"Original Tread Depth" is the tread depth of a new tire measured at the point of tread-indicator where available or one-fourth the width of the tire crown section from the crown center, including 24-hour inflation growth.



3. Classification

3.1 Uses and Characteristics of Off-The-Road Tires

The characteristics that Off-The-Road tires must possess differ according to their function and the type of vehicles they are mounted on.

TYPE / SERVICE	FUNCTION	VEHICLES	MAIN TIRE CHARACTERISTICS
EARTHMOVER	TRANSPORTING	 Rigid dump trucks  Articulated dump trucks  Coal haulers  Scrapers  Off road trucks	HEAT-RESISTANCE, CUT-RESISTANCE, WEAR-RESISTANCE SHOCK BURST-RESISTANCE
GRADER	GRADING, LEVELING	 Graders	TRACTION, MANEUVERABILITY, (DIRECTIONAL STABILITY)
LOADER AND DOZER	LOADING AND DOZING	 Loaders, Bulldozers	CUT-RESISTANCE, WEAR-RESISTANCE STABILITY
COMPACTOR	COMPACTING	 Tire-rollers	OIL-RESISTANCE, CUT-RESISTANCE, WEAR-RESISTANCE
LOGGING	LOG-SKIDDING	 Log-skidders	TRACTION, FLOTATION, CUT-RESISTANCE
MOBILE CRANE (HIGH-SPEED)	HIGH-SPEED TRAVELLING	 All-Terrain Cranes	HEAT-RESISTANCE, WEAR-RESISTANCE, TRACTION
INDUSTRIAL	HANDLING & TOWING	 Handling & Towing Equipments	UNEVEN WEAR, WEAR-RESISTANCE, STABILITY
UNDERGROUND	UNDERGROUND	 LHDs  Drilling Jumbo  Underground Trucks	CUT-RESISTANCE, WEAR-RESISTANCE

3.2 TRA Classification and Corresponding Firestone Off-The-Road Tires

Off-The-Road tires are classified by the TRA as follows, and the names of the tread patterns of the corresponding Firestone Off-The-Road tires are described below.

TRA CLASSIFICATION	TREAD TYPE	FIRESTONE TREAD PATTERN	
		RADIAL	BIAS
E= Earthmover (Haulage Service)			
E-2	Traction		SGG, SDT LD
E-3	Rock	VERSABUILT AP	SRG, SRG LD
E-4	Rock Deep	VERSABUILT DT	SRG DT
E-7	Flotation		DURAFORCE AP, SRG DT, SAND CHAMPION
G=Grader			
G-2	Traction	VERSABUILT AT	SGG LD, SGG RB, SGG MH
G-4	Rock Deep		SRG DT, SRG DT RB
L=Loader & Dozer (Slow Speed Service)			
L-2	Traction Regular	VERSABUILT AT	SGG, SGG LD, SGG MH, SGG RB, SDT LD
L-3	Rock Regular	VERSABUILT AP	SRG, DURAFORCE MH, SRG LD, SGG LD
L-4	Rock Deep	VERSABUILT DT	DURALOAD DT, SRG DT LD
L-5	Rock Extra-Deep		DURALOAD SDT, SDT LD, PTLD UMS, HTLD
L-5S	Smooth Extra-Deep		DURALOAD PT, HTLD, PTLD, PTLD UMS
Industrial Service			
Industrial Service			SRG, SRG DT, SRG DT LD, PT, PTLD

Design Tread-Depth

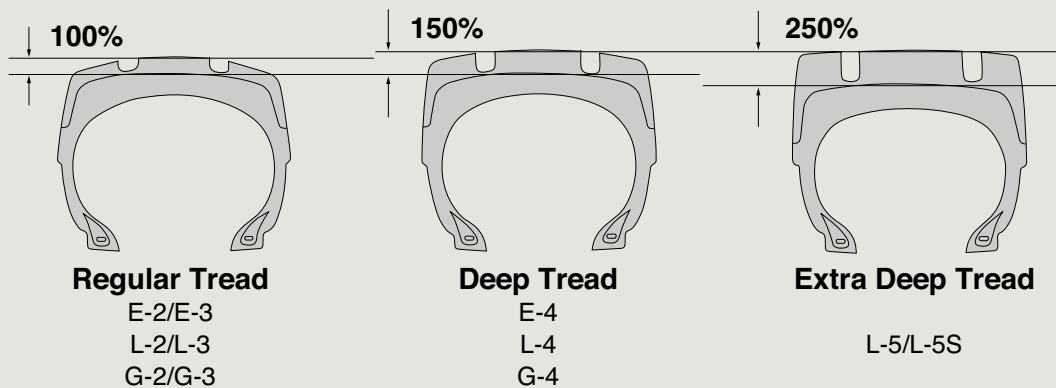

4.0 Tire Markings *Tire Location & Spec May Vary



1. Brand Name
2. Firestone's Specifications Code
3. Pattern Name
4. Tire Size
5. Serial Code

4.1 Type of Tire Size Designation

Regular	27.00 - 49 48PR	<div style="margin-left: 20px;"> <div style="margin-left: 20px;">Ply Rating</div> <div style="margin-left: 20px;">Rim Diameter (inches)</div> </div> <div style="margin-left: 10px;">Section Width (inches)</div>
Wide Base	33.25 - 35 38PR	<div style="margin-left: 20px;"> <div style="margin-left: 20px;">Ply Rating</div> <div style="margin-left: 20px;">Rim Diameter (inches)</div> </div> <div style="margin-left: 10px;">Section Width (inches)</div>
Super Wide Base	45 / 65 - 39 46PR	<div style="margin-left: 20px;"> <div style="margin-left: 20px;">Ply Rating</div> <div style="margin-left: 20px;">Rim Diameter (inches)</div> <div style="margin-left: 20px;">Aspect Ratio 65 Series</div> </div> <div style="margin-left: 10px;">Section Width (inches)</div>

*Tire Aspect Ratio

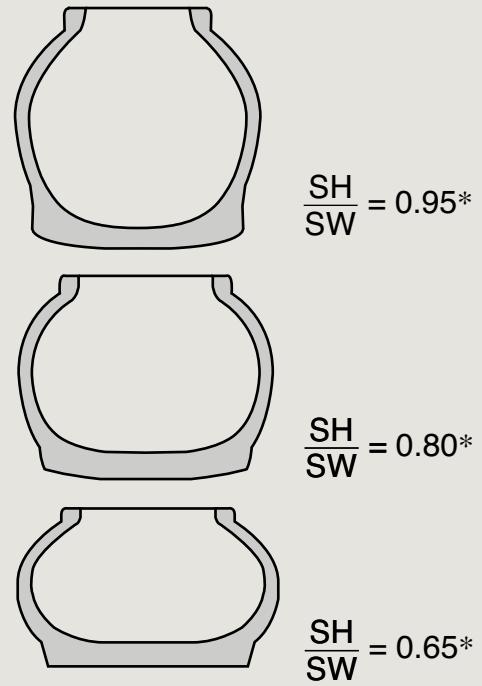

SH, SW : See Page 6

4.2 Type of Tire Structures Classified by Service and Designated by Firestone Radial (Versabuilt)

Each Firestone Radial (VersaBuilt) tire has a Firestone code number on the tire sidewall according to its specifications.

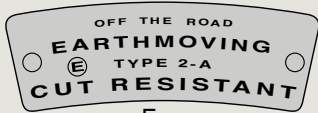

For
Earthmover service

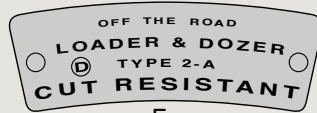

For
Loader and Dozer service

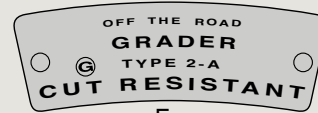

For
Grader service



For
Industrial service

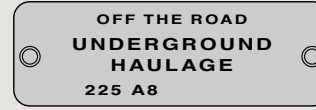

For
Underground Truck Service

Tire Structures Classified by Type of Service and Firestone's Radial Designations

TRA CLASSIFICATION	BSCODENO.	STRUCTURE
Earthmover Service (E)	1A	Standard
	2A	Cut-resistant
	3A	Heat-resistant
Grader Service (G)	1A	Standard
	2A	Cut-resistant
Loader & Dozer Service (D)	2A	Cut-resistant

4.3 Load Index

The LOAD INDEX is an international numerical code for the maximum load a tire can carry at the speed indicated by its speed symbol under service conditions specified by Firestone.

LI	kg	LI	kg	LI	kg	LI	kg	LI	kg	LI	kg
0	45	50	190	100	800	150	3 350	200	14 000	250	60 000
1	46.2	51	195	101	825	151	3 450	201	14 500	251	61 500
2	47.5	52	200	102	850	152	3 550	202	15 000	252	63 000
3	48.7	53	206	103	875	153	3 650	203	15 500	253	65 000
4	50	54	212	104	900	154	3 750	204	16 000	254	67 000
5	51.5	55	218	105	925	155	3 875	205	16 500	255	69 000
6	53	56	224	106	950	156	4 000	206	17 000	256	71 000
7	54.5	57	230	107	975	157	4 125	207	17 500	257	73 000
8	56	58	236	108	1 000	158	4 250	208	18 000	258	75 000
9	58	59	243	109	1 030	159	4 375	209	18 500	259	77 500
10	60	60	250	110	1 060	160	4 500	210	19 000	260	80 000
11	61.5	61	257	111	1 090	161	4 625	211	19 500	261	82 500
12	63	62	265	112	1 120	162	4 750	212	20 000	262	85 000
13	65	63	272	113	1 150	163	4 875	213	20 600	263	87 500
14	67	64	280	114	1 180	164	5 000	214	21 200	264	90 000
15	69	65	290	115	1 215	165	5 150	215	21 800	265	92 500
16	71	66	300	116	1 250	166	5 300	216	22 400	266	95 000
17	73	67	307	117	1 285	167	5 450	217	23 000	267	97 500
18	75	68	315	118	1 320	168	5 600	218	23 600	268	100 000
19	77.5	69	325	119	1 360	169	5 800	219	24 300	269	103 000
20	80	70	335	120	1 400	170	6 000	220	25 000	270	106 000
21	82.5	71	345	121	1 450	171	6 150	221	25 750	271	109 000
22	85	72	355	122	1 500	172	6 300	222	26 500	272	112 000
23	87.5	73	365	123	1 550	173	6 500	223	27 250	273	115 000
24	90	74	375	124	1 600	174	6 700	224	28 000	274	118 000
25	92.5	75	387	125	1 650	175	6 900	225	29 000	275	121 000
26	95	76	400	126	1 700	176	7 100	226	30 000	276	125 000
27	97	77	412	127	1 750	177	7 300	227	30 750	277	128 000
28	100	78	425	128	1 800	178	7 500	228	31 500	278	132 500
29	103	79	437	129	1 850	179	7 750	229	32 500	279	136 000
30	106	80	450	130	1 900	180	8 000	230	33 500		
31	109	81	462	131	1 950	181	8 250	231	34 500		
32	112	82	475	132	2 000	182	8 500	232	35 500		
33	115	83	487	133	2 060	183	8 750	233	36 500		
34	118	84	500	134	2 120	184	9 000	234	37 500		
35	121	85	515	135	2 180	185	9 250	235	38 750		
36	125	86	530	136	2 240	186	9 500	236	40 000		
37	128	87	545	137	2 300	187	9 750	237	41 250		
38	132	88	560	138	2 360	188	10 000	238	42 500		
39	136	89	580	139	2 430	189	10 300	239	43 750		
40	140	90	600	140	2 500	190	10 600	240	45 000		
41	145	91	615	141	2 575	191	10 900	241	46 250		
42	150	92	630	142	2 650	192	11 200	242	47 500		
43	155	93	650	143	2 725	193	11 500	243	48 750		
44	160	94	670	144	2 800	194	11 800	244	50 000		
45	165	95	690	145	2 900	195	12 150	245	51 500		
46	170	96	710	146	3 000	196	12 500	246	53 000		
47	175	97	730	147	3 075	197	12 850	247	54 500		
48	180	98	750	148	3 150	198	13 200	248	56 000		
49	185	99	775	149	3 250	199	13 600	249	58 000		

4.4 Speed Symbol

The SPEED SYMBOL indicates the speed at which the tire can carry a load corresponding to its load index under service conditions specified by Firestone.

Speed Symbol	Speed (km/h)
A1	5
A2	10
A3	15
A4	20
A5	25
A6	30
A7	35
A8	40

Speed Symbol	Speed (km/h)
B	50
C	60
D	65
E	70
F	80
G	90

4.5 Conversion Table: Star Rating to Ply Rating

Service	Tire Size	Star Rating	Corresponding Ply Rating
Earthmover	12.00R24	★3	up to 24
	14.00R24	★3	up to 32
	14.00R25	★3	up to 32
	16.00R25	★2	up to 36
	18.00R25	★1	up to 24
		★2	up to 36
	18.00R33	★2	up to 40
	21.00R35	★2	up to 44
	40.00R57	★2	up to 74
	17.5R25	★1	up to 16
	20.5R25	★1	up to 24
		★2	up to 28
	23.5R25	★1	up to 24
		★2	up to 32
	26.5R25	★2	up to 32
	29.5R25	★2	up to 34
	29.5R29	★2	up to 40
	33.25R29	★2	up to 44
	33.25R35	★2	up to 44
	37.25R35	★2	up to 48
37.5R39	★2	up to 52	
40.5/75R39	★2	up to 54	

Service	Tire Size	Star Rating	Corresponding Ply Rating
Grader	14.00R24	★1	up to 16
	16.00R24	★1	up to 16
	17.5R25	★1	up to 16
Loader	15.5R25	★1	up to 16
	17.5R25	★1	up to 16
	20.5R25	★1	up to 24
		★2	up to 28
	23.5R25	★1	up to 24
		★2	up to 32
	26.5R25	★1	up to 24
		★2	up to 36
	29.5R25	★1	up to 28
		★2	up to 34
	29.5R29	★1	up to 34
	35/65R33	★1	up to 36
	45/65R45	★1	up to 50
50/65R51	★2	up to 54	

4.6 Size Conversion Table

Metric	Inch
385/95R24, 25	14.00R24, 25
445/95R24, 25	16.00R24, 25
445/80R25	17.5R25
505/95R25	18.00R25
525/80R25	20.5R25
750/65R25	30/65R25

4.7 Multiple Star Rating

Firestone Radial Tires marked with "LOADER & DOZER #(one star)" and "EARTHMOVER ##(two star)" have specified load capacity on each servicing condition.

Strength of tire casing is designed to constrain inflation pressure used.

<26.5R25 as an example>

	Type of Service	Star Rating	Inflation Pressure	Load (Load Index)	Speed (Speed Symbol)
MS	Loader	★(one star)	5.00 bar	15,000 kgs (202)	10 km/hour (A2)
	Earthmover	★★(two stars)	5.25 bar	11,500 kgs (193)	50 km/hour (B)



RADIAL TIRES



14.00R24

	PLY/STAR RATING	TRA / APPLICATION	SPEC	ARTICLE #	RECOMMENDED RIM/FLANGE HEIGHT [INCH]	APPROXIMATE INFLATED DIMENSIONS				
						OD [INCH / MM]	OW [INCH / MM]	SLR [INCH / MM]	SLW [INCH / MM]	OTD [32ND / MM]
VERSABUILT AT	1*	G-2	-	5639	10.00 W	53.3 1,353	15.7 398	24.1 613	17.6 448	34 27.0

GRADER - VERSABUILT AT

MAX SPEED 25 MPH | 40 KPH

TIRE LOAD LIMITS AT VARIOUS COLD INFLATION PRESSURES

PSI	29	33	36	40	44	47	51	54
KPA	200	225	250	275	300	325	350	375
LBS	4,940	5,360	5,840	6,150	6,600	7,150	7,400	8,050
KG	2,240	2,430	2,650	2,800	3,000	3,250	3,350	3,650

1*

17.5R25

	PLY/STAR RATING	TRA / APPLICATION	SPEC	ARTICLE #	RECOMMENDED RIM/FLANGE HEIGHT [INCH]	APPROXIMATE INFLATED DIMENSIONS				
						OD [INCH / MM]	OW [INCH / MM]	SLR [INCH / MM]	SLW [INCH / MM]	OTD [32ND / MM]
VERSABUILT AP	MS	E-3, L-3	-	5498	14.00/1.5	52.9 1,344	17.2 438	23.6 599	-	32 25.0
VERSABUILT AT	1*	G-2, L-2	-	5507	14.00/1.5	52.8 1,342	17.4 442	23.5 597	-	35 28.0

EARTHMOVER - VERSABUILT AP

MAX SPEED 30 MPH | 50 KPH

TIRE LOAD LIMITS AT VARIOUS COLD INFLATION PRESSURES

PSI	40	44	47	51	54	58	62	65	69	73	76
KPA	275	300	325	350	375	400	425	450	475	500	525
LBS	7,400	7,850	8,250	8,800	9,100	9,650	10,200	10,500	11,000	11,400	12,000
KG	3,350	3,550	3,750	4,000	4,125	4,375	4,625	4,750	5,000	5,150	5,450

2*

GRADER - VERSABUILT AT*

MAX SPEED 25 MPH | 40 KPH

TIRE LOAD LIMITS AT VARIOUS COLD INFLATION PRESSURES

PSI	18	22	25	29	33	36	40	44
KPA	125	150	175	200	225	250	275	300
LBS	4,080	4,680	5,200	5,840	6,400	6,800	7,400	8,050
KG	1,850	2,120	2,360	2,650	2,900	3,075	3,350	3,650

1*

LOADER - VERSABUILT AP, VERSABUILT AT

MAX SPEED 5 MPH | 10 KPH

TIRE LOAD LIMITS AT VARIOUS COLD INFLATION PRESSURES

PSI	58	62	65	69	73
KPA	400	425	450	475	500
LBS	13,200	13,600	14,300	14,800	15,700
KG	6,000	6,150	6,500	6,700	7,100

1*

* For slope and ditching service, inflation pressures should be increased by 15 psi (100kPa) with no increase in load rating. For extreme conditions, consult a Firestone Representative for additional recommended operating requirements.

20.5R25

	PLY/STAR RATING	TRA / APPLICATION	SPEC	ARTICLE #	RECOMMENDED RIM/FLANGE HEIGHT [INCH]	APPROXIMATE INFLATED DIMENSIONS				
						OD [INCH / MM]	OW [INCH / MM]	SLR [INCH / MM]	SLW [INCH / MM]	OTD [32ND / MM]
VERSABUILT AP	MS	E-3, L-3	-	5499	17.00/2.0	58.4 1,483	20.8 527	25.9 658	- -	37 29.0
VERSABUILT AT	1*	G-2, L-2	-	5508	17.00/2.0	58.1 1,475	21.0 534	- -	- -	40 32.0

EARTHMOVER - VERSABUILT AP **MAX SPEED 30 MPH | 50 KPH**

TIRE LOAD LIMITS AT VARIOUS COLD INFLATION PRESSURES

PSI	40	44	47	51	54	58	62	65	69	73	76
KPA	275	300	325	350	375	400	425	450	475	500	525
LBS	9,650	10,500	11,000	11,700	12,300	12,800	13,600	14,300	14,800	15,200	16,100
KG	4,375	4,750	5,000	5,300	5,600	5,800	6,150	6,500	6,700	6,900	7,300

2*

GRADER - VERSABUILT AT* **MAX SPEED 25 MPH | 40 KPH**

TIRE LOAD LIMITS AT VARIOUS COLD INFLATION PRESSURES

PSI	18	22	25	29	33	36	40	44
KPA	125	150	175	200	225	250	275	300
LBS	5,360	6,150	6,950	7,600	8,550	9,100	9,650	10,200
KG	2,430	2,800	3,150	3,450	3,875	4,125	4,375	4,625

1*

LOADER - VERSABUILT AP, VERSABUILT AT **MAX SPEED 5 MPH | 10 KPH**

TIRE LOAD LIMITS AT VARIOUS COLD INFLATION PRESSURES

PSI	58	62	65	69	73
KPA	400	425	450	475	500
LBS	17,600	18,200	19,300	19,800	20,900
KG	8,000	8,250	8,750	9,000	9,500

1*

* For slope and ditching service, inflation pressures should be increased by 15 psi (100kPa) with no increase in load rating. For extreme conditions, consult a Firestone Representative for additional recommended operating requirements.



23.5R25

	PLY/STAR RATING	TRA / APPLICATION	SPEC	ARTICLE #	RECOMMENDED RIM/FLANGE HEIGHT [INCH]	APPROXIMATE INFLATED DIMENSIONS				
						OD [INCH / MM]	OW [INCH / MM]	SLR [INCH / MM]	SLW [INCH / MM]	OTD [32ND / MM]
VERSABUILT AP	MS	E-3, L-3	-	5501	19.50/2.5	63.1 1,603	24.3 617	27.7 704	- -	42 33.0
VERSABUILT AT	1*	G-2, L-2	-	5509	19.50/2.5	63.0 1,599	24.3 617	- -	- -	44 35.0
VERSABUILT DT	MS	E-4, L-4	-	5504	19.50/2.5	65.3 1,658	24.1 613	- -	- -	79 63.0

EARTHMOVER - VERSABUILT AP, VERSABUILT DT **MAX SPEED 30 MPH | 50 KPH**

TIRE LOAD LIMITS AT VARIOUS COLD INFLATION PRESSURES

PSI	40	44	47	51	54	58	62	65	69	73	76
KPA	275	300	325	350	375	400	425	450	475	500	525
LBS	12,300	13,200	14,300	14,800	15,700	16,500	17,100	18,200	18,700	19,800	20,400
KG	5,600	6,000	6,500	6,700	7,100	7,500	7,750	8,250	8,500	9,000	9,250

2*

GRADER - VERSABUILT AT* **MAX SPEED 25 MPH | 40 KPH**

TIRE LOAD LIMITS AT VARIOUS COLD INFLATION PRESSURES

PSI	18	22	25	29	33	36	40	44
KPA	125	150	175	200	225	250	275	300
LBS	6,950	7,850	8,800	9,900	10,700	11,700	12,300	13,200
KG	3,150	3,550	4,000	4,500	4,875	5,300	5,600	6,000

1*

LOADER - VERSABUILT AP, VERSABUILT AT, VERSABUILT DT **MAX SPEED 5 MPH | 10 KPH**

TIRE LOAD LIMITS AT VARIOUS COLD INFLATION PRESSURES

PSI	58	62	65	69	73
KPA	400	425	450	475	500
LBS	22,700	23,400	24,700	25,400	26,800
KG	10,300	10,600	11,200	11,500	12,150

1*

* For slope and ditching service, inflation pressures should be increased by 15 psi (100kPa) with no increase in load rating. For extreme conditions, consult a Firestone Representative for additional recommended operating requirements.

26.5R25

	PLY/STAR RATING	TRA / APPLICATION	SPEC	ARTICLE #	RECOMMENDED RIM/FLANGE HEIGHT [INCH]	APPROXIMATE INFLATED DIMENSIONS				
						OD [INCH / MM]	OW [INCH / MM]	SLR [INCH / MM]	SLW [INCH / MM]	OTD [32ND / MM]
VERSABUILT AP	MS	E-3, L-3	-	5502	22.00/3.0	68.2 1,732	27.0 685	29.9 759	- -	44 35.0
VERSABUILT DT	MS	E-4, L-4	-	5505	22.00/3.0	69.6 1,767	27.0 685	30.7 780	- -	69 54.0

EARTHMOVER - VERSABUILT AP, VERSABUILT DT **MAX SPEED 30 MPH | 50 KPH**

TIRE LOAD LIMITS AT VARIOUS COLD INFLATION PRESSURES

PSI	40	44	47	51	54	58	62	65	69	73	76
KPA	275	300	325	350	375	400	425	450	475	500	525
LBS	15,700	16,500	17,600	18,700	19,800	20,900	21,500	22,700	23,400	24,700	25,400
KG	7,100	7,500	8,000	8,500	9,000	9,500	9,750	10,300	10,600	11,200	11,500

2*

LOADER - VERSABUILT AP, VERSABUILT DT **MAX SPEED 5 MPH | 10 KPH**

TIRE LOAD LIMITS AT VARIOUS COLD INFLATION PRESSURES

PSI	58	62	65	69	73
KPA	400	425	450	475	500
LBS	28,300	29,100	30,900	32,000	33,100
KG	12,850	13,200	14,000	14,500	15,000

1*

29.5R25

	PLY/STAR RATING	TRA / APPLICATION	SPEC	ARTICLE #	RECOMMENDED RIM/FLANGE HEIGHT [INCH]	APPROXIMATE INFLATED DIMENSIONS				
						OD [INCH / MM]	OW [INCH / MM]	SLR [INCH / MM]	SLW [INCH / MM]	OTD [32ND / MM]
VERSABUILT AP	MS	E-3, L-3	-	5503	25.00/3.5	73.1 1,856	30.4 772	31.9 810	- -	48 38.0
VERSABUILT DT	MS	E-4, L-4	-	5506	25.00/3.5	74.5 1,891	30.4 772	32.6 828	- -	76 61.0

EARTHMOVER - VERSABUILT AP, VERSABUILT DT **MAX SPEED 30 MPH | 50 KPH**

TIRE LOAD LIMITS AT VARIOUS COLD INFLATION PRESSURES

PSI	40	44	47	51	54	58	62	65	69	73	76
KPA	275	300	325	350	375	400	425	450	475	500	525
LBS	18,700	20,400	21,500	22,700	24,000	25,400	26,000	27,600	28,300	30,000	30,900
KG	8,500	9,250	9,750	10,300	10,900	11,500	11,800	12,500	12,850	13,600	14,000

2*

LOADER - VERSABUILT AP, VERSABUILT DT **MAX SPEED 5 MPH | 10 KPH**

TIRE LOAD LIMITS AT VARIOUS COLD INFLATION PRESSURES

PSI	58	62	65	69	73
KPA	400	425	450	475	500
LBS	34,200	35,300	37,500	38,600	39,700
KG	15,500	16,000	17,000	17,500	18,000

1*



BIAS TIRES

13.00 - 24 TUBELESS

	PLY RATING	TRA / APPLICATION	SPEC	ARTICLE #	APPROXIMATE INFLATED DIMENSIONS					MINIMUM DUAL SPACING [INCH]	RECOMMENDED RIM / FLANGE HEIGHT [INCH]
					OD [INCH / MM]	OW [INCH / MM]	SLR [INCH / MM]	SLW [INCH / MM]	OTD [32ND / MM]		
SGG RB (SGG MH)	12	G-2, L-2	MH	429209	50.3 1,278	14.5 368	23.0 584	15.9 404	29 23.0	-	8.00TG
SGG RB	16	G-2, L-2	-	425163	50.3 1,278	14.5 368	23.0 584	15.9 404	29 23.0	-	8.00TG

GRADER - SGG RB, SGG MH

MAX SPEED 25 MPH | 40 KPH

TIRE LOAD LIMITS AT VARIOUS COLD INFLATION PRESSURES

	18 KPA	22 150	25 175	29 200	33 225	36 250	40 275	44 300	47 325	51 350
PSI	125	150	175	200	225	250	275	300	325	350
LBS	3,740	4,180	4,540	4,940	5,200	5,520	5,840	6,000	6,400	6,800
KG	1,700	1,900	2,060	2,240	2,360	2,500	2,650	2,725	2,900	3,075

LOADER - SGG RB, SGG MH

MAX SPEED 5 MPH | 10 KPH

TIRE LOAD LIMITS AT VARIOUS COLD INFLATION PRESSURES

	47 KPA	51 350	54 375	58 400	62 425	65 450	69 475	73 500	76 525	80 550	83 575
PSI	325	350	375	400	425	450	475	500	525	550	575
LBS	9,900	10,500	11,000	11,400	11,700	12,300	12,300	12,800	13,200	13,600	14,300
KG	4,500	4,750	5,000	5,150	5,300	5,600	5,600	5,800	6,000	6,150	6,500

14.00 - 24 TUBELESS

	PLY RATING	TRA / APPLICATION	SPEC	ARTICLE #	APPROXIMATE INFLATED DIMENSIONS					MINIMUM DUAL SPACING [INCH]	RECOMMENDED RIM / FLANGE HEIGHT [INCH]
					OD [INCH / MM]	OW [INCH / MM]	SLR [INCH / MM]	SLW [INCH / MM]	OTD [32ND / MM]		
SRG DT RB	12	G-4	-	425656	54.7 1,389	15.2 386	25.4 645	16.9 429	58 46.0	-	8.00TG
SGG RB	12	G-2/L-2	-	425214	53.2 1,351	16.0 406	24.2 615	18.1 460	31 24.5	-	8.00TG
SGG RB	16	G-2/L-2	-	425384	53.2 1,351	16.0 406	24 615	18.1 460	31 24.5	-	10.00VA

GRADER - SRG DT RB, SGG RB

MAX SPEED 25 MPH | 40 KPH

TIRE LOAD LIMITS AT VARIOUS COLD INFLATION PRESSURES

	18 KPA	22 150	25 175	29 200	33 225	36 250	40 275	44 300	47 325	51 350
PSI	125	150	175	200	225	250	275	300	325	350
LBS	4,540	5,080	5,520	5,840	6,150	6,800	7,150	7,600	7,850	8,050
KG	2,060	2,300	2,500	2,650	2,800	3,075	3,250	3,450	3,550	3,650

LOADER - SGG RB

MAX SPEED 5 MPH | 10 KPH

TIRE LOAD LIMITS AT VARIOUS COLD INFLATION PRESSURES

	62 KPA	65 450	69 475	73 500	76 525	80 550
PSI	425	450	475	500	525	550
LBS	13,900	14,300	14,800	15,200	15,700	16,100
KG	6,300	6,500	6,700	6,900	7,100	7,300



16.00 - 24 TUBELESS

	PLY RATING	TRA / APPLICATION	SPEC	ARTICLE #	APPROXIMATE INFLATED DIMENSIONS					MINIMUM DUAL SPACING [INCH]	RECOMMENDED RIM / FLANGE HEIGHT [INCH]
					OD [INCH / MM]	OW [INCH / MM]	SLR [INCH / MM]	SLW [INCH / MM]	OTD [32ND / MM]		
SGG RB	16	G-2	-	426166	57.4 1,458	17.7 450	26.0 660	20.0 508	31 24.5	- -	10.00VA

GRADER - SGG RB

MAX SPEED 25 MPH | 40 KPH

TIRE LOAD LIMITS AT VARIOUS COLD INFLATION PRESSURES

	18 KPA	22 150	25 175	29 200	33 225	36 250	40 275	44 300
LBS	5,840	6,600	7,150	7,600	8,050	8,800	9,350	9,900
KG	2,650	3,000	3,250	3,450	3,650	4,000	4,250	4,500

16 PLY

15.5 - 25 TUBELESS

	PLY RATING	TRA / APPLICATION	SPEC	ARTICLE #	APPROXIMATE INFLATED DIMENSIONS					MINIMUM DUAL SPACING [INCH]	RECOMMENDED RIM / FLANGE HEIGHT [INCH]
					OD [INCH / MM]	OW [INCH / MM]	SLR [INCH / MM]	SLW [INCH / MM]	OTD [32ND / MM]		
SGG LD	12	L-2	LD	425248	50.0 1,270	15.8 401	22.3 566	17.9 455	29 23.0	- -	12.00/1.5

LOADER - SGG LD

MAX SPEED 5 MPH | 10 KPH

TIRE LOAD LIMITS AT VARIOUS COLD INFLATION PRESSURES

	33 KPA	36 250	40 275	44 300	47 325	51 350	54 375	58 400
LBS	8,800	9,350	9,900	10,500	10,700	11,400	11,700	12,300
KG	4,000	4,250	4,500	4,750	4,875	5,150	5,300	5,600

12 PLY

16.00 - 25 TUBELESS

	PLY RATING	TRA / APPLICATION	SPEC	ARTICLE #	APPROXIMATE INFLATED DIMENSIONS					MINIMUM DUAL SPACING [INCH]	RECOMMENDED RIM / FLANGE HEIGHT [INCH]
					OD [INCH / MM]	OW [INCH / MM]	SLR [INCH / MM]	SLW [INCH / MM]	OTD [32ND / MM]		
SRG	28	E-3	-	413518	58.8 1,493	17.2 437	27.2 691	18.8 478	36 28.5	20.2 513	11.25/2.0
SRG DT	28	E-4	-	423149	60.2 1,529	17.2 437	28.2 716	18.9 480	62 49.0	20.2 513	11.25/2.0

EARTHMOVER - SRG, SRG DT,

MAX SPEED 30 MPH | 50 KPH

TIRE LOAD LIMITS AT VARIOUS COLD INFLATION PRESSURES

PSI	36	40	44	47	51	54	58	62	65	69	73	76	80	83
KPA	250	275	300	325	350	375	400	425	450	475	500	525	550	575
LBS	9,100	9,650	10,200	10,700	11,000	11,700	12,000	12,300	12,800	13,200	13,900	14,300	14,300	14,800
KG	4,125	4,375	4,625	4,875	5,000	5,300	5,450	5,600	5,800	6,000	6,300	6,500	6,500	6,700

28 PLY

17.5 - 25 TUBELESS

	PLY RATING	TRA / APPLICATION	SPEC	ARTICLE #	APPROXIMATE INFLATED DIMENSIONS					MINIMUM DUAL SPACING [INCH]	RECOMMENDED RIM / FLANGE HEIGHT [INCH]
					OD [INCH / MM]	OW [INCH / MM]	SLR [INCH / MM]	SLW [INCH / MM]	OTD [32ND / MM]		
SGG LD	12	G-2, L-2	LD	425129	53.6 1,361	18.0 457	23.7 602	20.3 516	31 24.5	-	14.00/1.5
SGG LD	16	L-2	LD	425180	53.6 1,361	18.0 457	23.7 602	20.3 516	31 24.5	-	14.00/1.5
SGG LD	20	L-2	LD	429243	53.6 1,361	18.0 457	23.7 602	20.3 516	31 24.5	-	14.00/1.5
SGG LD	12	L-3	LD CRC	425537	53.4 1,365	18.0 457	24.0 610	20.3 516	32 25.5	-	14.00/1.5
SGG LD	16	L-3	LD	425554	53.4 1,365	18.0 457	24.0 610	20.3 516	32 25.5	-	14.00/1.5
SGG LD	20	L-3	LD	425571	53.4 1,365	18.0 457	24.0 610	20.3 516	32 25.5	-	14.00/1.5

GRADER - SGG

MAX SPEED 25 MPH | 40 KPH

TIRE LOAD LIMITS AT VARIOUS COLD INFLATION PRESSURES

PSI	18	22	25	29	33	36	40	44	47
KPA	125	150	175	200	225	250	275	300	325
LBS	4,680	5,200	5,680	6,400	6,600	6,950	7,400	7,850	8,50
KG	2,120	2,360	2,575	2,900	3,000	3,150	3,350	3,550	3,650

12 PLY

LOADER - PTL D UMS, SGG, SGG LD, SRG, SRG DT

MAX SPEED 5 MPH | 10 KPH

TIRE LOAD LIMITS AT VARIOUS COLD INFLATION PRESSURES

PSI	33	36	40	44	47	51	54	58	62	65	69	73	76	80	83
KPA	225	250	275	300	325	350	375	400	425	450	475	500	525	550	575
LBS	10,500	11,000	11,700	12,300	12,800	13,600	13,900	14,800	15,200	15,700	16,100	16,500	17,100	17,600	18,200
KG	4,750	5,000	5,300	5,600	5,800	6,150	6,300	6,700	6,900	7,100	7,300	7,500	7,750	8,000	8,250

12 PLY

16 PLY

20 PLY



18.00 - 25 TUBELESS

	PLY RATING	TRA / APPLICATION	SPEC	ARTICLE #	APPROXIMATE INFLATED DIMENSIONS					MINIMUM DUAL SPACING [INCH]	RECOMMENDED RIM / FLANGE HEIGHT [INCH]
					OD [INCH / MM]	OW [INCH / MM]	SLR [INCH / MM]	SLW [INCH / MM]	OTD [32ND / MM]		
DURAFORCE AP	16	E-7	NY	1277	59.9 1,521	18.8 478	23.3 592	- -	16 12.7	- -	13.00/2.5
PT	40	IND-4S	IDU	5524	66.1 1,679.0	20.9 531.0	30.3 770.0	22.3 566.0	69 55.0	- -	13.00/2.5
PTLD UMS	32	L-5S	UMS	416819	65.9 1,674	19.6 498	30.1 765	22.5 571	97 77.0	- -	13.00/2.5
SRG DT	32	E-4	-	403172	64.5 1,638	20.0 508	30.1 765	22.5 571	69 55.0	23.1 587	13.00/2.5
SRG DT	40	IND-4	IDU	426064	64.5 1,638	20.0 508	22.5 571	30.1 765	69 55.0	23.1 587	13.00/2.5

EARTHMOVER - SRG DT **MAX SPEED 30 MPH | 50 KPH**

TIRE LOAD LIMITS AT VARIOUS COLD INFLATION PRESSURES

	40	44	47	51	54	58	62	65	69	73	76	80	83
PSI	40	44	47	51	54	58	62	65	69	73	76	80	83
KPA	275	300	325	350	375	400	425	450	475	500	525	550	575
LBS	12,300	13,200	13,900	14,300	15,200	15,700	16,100	16,500	17,100	17,600	18,200	18,700	19,300
KG	5,600	6,000	6,300	6,500	6,900	7,100	7,300	7,500	7,750	8,000	8,250	8,500	8,750

32 PLY

FLOTATION - DURAFORCE AP **MAX SPEED 40 MPH | 65 KPH**

TIRE LOAD LIMITS AT VARIOUS COLD INFLATION PRESSURES

	10	13	16	19	22	25	28	30	33	36
PSI	10	13	16	19	22	25	28	30	33	36
KPA	70	90	110	130	150	170	190	210	230	250
LBS	8,800	9,900	10,700	11,700	12,800	13,600	14,300	15,200	15,700	16,500
KG	4,000	4,500	4,875	5,300	5,800	6,150	6,500	6,900	7,100	7,500

16 PLY

FLOTATION - DURAFORCE AP **MAX SPEED 30 MPH | 50 KPH**

TIRE LOAD LIMITS AT VARIOUS COLD INFLATION PRESSURES

	10	13	16	19	22	25	28	30	33	36
PSI	10	13	16	19	22	25	28	30	33	36
KPA	70	90	110	130	150	170	190	210	230	250
LBS	6,150	6,800	7,400	8,050	8,550	9,100	9,650	10,200	10,700	11,400
KG	2,800	3,075	3,350	3,650	3,875	4,125	4,375	4,625	4,875	5,150

16 PLY

FLOTATION - DURAFORCE AP **MAX SPEED 5 MPH | 10 KPH**

TIRE LOAD LIMITS AT VARIOUS COLD INFLATION PRESSURES

	10	13	16	19	22	25	28	30	33	36
PSI	10	13	16	19	22	25	28	30	33	36
KPA	70	90	110	130	150	170	190	210	230	250
LBS	11,700	12,800	13,900	15,200	16,500	17,600	18,700	19,300	20,400	21,500
KG	5,300	5,800	6,300	6,900	7,500	8,000	8,500	8,750	9,250	9,750

16 PLY

INDUSTRIAL - PT, SRG DT - LOAD WHEEL

TIRE LOAD LIMITS AT VARIOUS COLD INFLATION PRESSURES

PSI	145									
KPA	1,000									
MPH	STATIC	CREEP	3	5	9	12	15	19		
KM/H	0	CREEP	5	10	15	20	25	30		
LBS	68,000	60,000	53,000	50,700	48,100	48,100	46,700	46,700		
KG	30,750	27,250	24,300	23,000	21,800	21,800	21,200	21,200		

40

18.00 - 25 TUBELESS [CONTINUED]

INDUSTRIAL - PT, SRG DT - STEERING WHEEL

TIRE LOAD LIMITS AT VARIOUS COLD INFLATION PRESSURES

PSI	145								
KPA	1,000								
MPH	STATIC	CREEP	3	5	9	12	15	19	
KM/H	0	CREEP	5	10	15	20	25	30	
LBS	55,100	48,100	43,000	40,800	37,600	37,600	37,500	37,500	
KG	25,000	21,800	19,500	18,500	17,500	17,500	17,000	17,000	

40

LOADER - PTL D UMS

MAX SPEED 5 MPH | 10 KPH

TIRE LOAD LIMITS AT VARIOUS COLD INFLATION PRESSURES

PSI	54	58	62	65	69	73	76	80	83	87	91	94	98	102	105	109
KPA	375	400	425	450	475	500	525	550	575	600	625	650	675	700	725	750
LBS	22,000	23,000	24,000	25,400	25,400	26,000	26,800	27,600	28,300	29,100	30,000	30,000	30,900	32,000	32,000	33,100
KG	10,000	10,450	10,900	11,500	11,500	11,800	12,150	12,500	12,850	13,200	13,600	13,600	14,000	14,500	14,500	15,000

32 PLY

20.5 - 25 TUBELESS

	PLY RATING	TRA / APPLICATION	SPEC	ARTICLE #	APPROXIMATE INFLATED DIMENSIONS					MINIMUM DUAL SPACING [INCH]	RECOMMENDED RIM / FLANGE HEIGHT [INCH]
					OD [INCH / MM]	OW [INCH / MM]	SLR [INCH / MM]	SLW [INCH / MM]	OTD [32ND / MM]		
SDT LD	16	L-5	-	403903	60.9 1,547	20.7 526	27.8 706	23.4 594	88 70.0	-	17.00/2.0
SDT LD	20	L-5	-	417610	60.9 1,547	20.7 526	27.8 706	23.4 594	88 70.0	-	17.00/2.0
SGG LD	16	E-2, L-2	LD	408492	58.5 1,486	21.0 533	25.8 655	23.7 602	35 28.0	-	17.00/2.0
SRG LD	16	E-3, L-3	LD	408476	59.0 1,499	21.1 536	26.1 663	23.8 605	35 28.0	-	17.00/2.0
SRG LD	20	E-3, L-3	LD	414646	59.0 1,499	21.1 536	26.1 663	23.8 605	35 28.0	-	17.00/2.0

EARTHMOVER - SGG LD, SRG LD

MAX SPEED 30 MPH | 50 KPH

TIRE LOAD LIMITS AT VARIOUS COLD INFLATION PRESSURES

PSI	25	29	33	36	40	44	47
KPA	175	200	225	250	275	300	325
LBS	9,100	9,900	10,700	11,400	12,000	12,800	13,200
KG	4,125	4,500	4,875	5,150	5,450	5,800	6,000

16 PLY

20 PLY

LOADER - SDT LD, SGG LD, SRG LD

MAX SPEED 5 MPH | 10 KPH

TIRE LOAD LIMITS AT VARIOUS COLD INFLATION PRESSURES

PSI	33	36	40	44	47	51	54	58	62	65
KPA	225	250	275	300	325	350	375	400	425	450
LBS	13,900	14,800	15,700	16,500	17,100	18,200	18,700	19,300	20,400	20,900
KG	6,300	6,700	7,100	7,500	7,750	8,250	8,500	8,750	9,250	9,500

16 PLY

20 PLY



21.00 - 25 TUBELESS

	PLY RATING	TRA / APPLICATION	SPEC	ARTICLE #	APPROXIMATE INFLATED DIMENSIONS					MINIMUM DUAL SPACING [INCH]	RECOMMENDED RIM / FLANGE HEIGHT [INCH]
					OD [INCH / MM]	OW [INCH / MM]	SLR [INCH / MM]	SLW [INCH / MM]	OTD [32ND / MM]		
DURAFORCE AP	16	E-7	NY	3771	67.1 1.704	23.8 605	27.6 701	- -	16.0 12.5	- -	15.00/3.0
PTLD UMS	32	L-5S	UMS	416983	70.8 1.798	22.5 572	31.4 798	24.3 617	110 87.5	- -	15.00/3.0

FLOTATION - DURAFORCE AP **MAX SPEED 40 MPH | 65 KPH**

TIRE LOAD LIMITS AT VARIOUS COLD INFLATION PRESSURES

	10	13	16	19	22	25	28	30	33	36
PSI	10	13	16	19	22	25	28	30	33	36
KPA	70	90	110	130	150	170	190	210	230	250
LBS	6,800	7,400	8,050	8,800	9,350	10,200	10,700	11,400	12,000	12,300
KG	3,075	3,350	3,650	4,000	4,250	4,625	4,874	5,150	5,450	5,600

16 PLY

FLOTATION - DURAFORCE AP **MAX SPEED 30 MPH | 50 KPH**

TIRE LOAD LIMITS AT VARIOUS COLD INFLATION PRESSURES

	10	13	16	19	22	25	28	30	33	36
PSI	10	13	16	19	22	25	28	30	33	36
KPA	70	90	110	130	150	170	190	210	230	250
LBS	8,050	8,000	9,650	10,500	11,000	12,000	12,800	13,200	13,900	14,800
KG	3,650	4,000	4,375	4,750	5,000	5,450	5,800	6,000	6,300	6,700

16 PLY

FLOTATION - DURAFORCE AP **MAX SPEED 5 MPH | 10 KPH**

TIRE LOAD LIMITS AT VARIOUS COLD INFLATION PRESSURES

	10	13	16	19	22	25	28	30	33	36
PSI	10	13	16	19	22	25	28	30	33	36
KPA	70	90	110	130	150	170	190	210	230	250
LBS	11,700	12,800	13,900	15,200	16,500	17,600	18,700	19,300	20,400	21,500
KG	5,300	5,800	6,300	6,900	7,500	8,000	8,500	8,750	9,250	9,750

16 PLY

LOADER - PTLD UMS **MAX SPEED 5 MPH | 10 KPH**

TIRE LOAD LIMITS AT VARIOUS COLD INFLATION PRESSURES

	54	58	62	65	69	73	76	80	83	87	91	94
PSI	54	58	62	65	69	73	76	80	83	87	91	94
KPA	375	400	425	450	475	500	525	550	575	600	625	650
LBS	28,300	29,100	30,900	32,000	32,000	33,100	34,200	35,300	36,400	37,500	38,600	38,600
KG	12,850	13,200	14,000	14,500	14,500	15,000	15,500	16,000	16,500	17,000	17,500	17,500

32 PLY

23.5 - 25 TUBELESS

	PLY RATING	TRA / APPLICATION	SPEC	ARTICLE #	APPROXIMATE INFLATED DIMENSIONS					MINIMUM DUAL SPACING [INCH]	RECOMMENDED RIM / FLANGE HEIGHT [INCH]
					OD [INCH / MM]	OW [INCH / MM]	SLR [INCH / MM]	SLW [INCH / MM]	OTD [32ND / MM]		
SDT LD	16	L-5	-	403911	65.9 1,674	24.4 620	30.3 770	27.6 701	98 78.0	- -	19.50/2.5
SDT LD	20	L-5	-	403970	65.9 1,674	24.4 620	30.3 770	27.6 701	98 78.0	- -	19.50/2.5
SGG	20	E-2, L-2	LD	404969	63.4 1,610	24.1 612	28.9 734	26.6 676	39 31.0	- -	19.50/2.5
SRG LD	20	E-3, L-3	LD	400610	63.9 1,623	24.2 615	28.8 732	26.9 683	39 31.0	- -	19.50/2.5
SRG DT LD	24	L-4		417459	65.9 1,674	23.5 597	29.4 74.7	25.4 645	67 53.0	- -	19.00/2.5

EARTHMOVER - SGG LD, SRG LD

MAX SPEED 30 MPH | 50 KPH

TIRE LOAD LIMITS AT VARIOUS COLD INFLATION PRESSURES

	25	29	33	36	40	44
PSI	25	29	33	36	40	44
KPA	175	200	225	250	275	300
LBS	11,700	12,800	13,600	14,300	15,200	16,100
KG	5,300	5,800	6,150	6,500	6,900	7,300
	16 PLY			20 PLY		

LOADER - SDT LD, SGG LD, SRG LD, SRG DT LD

MAX SPEED 5 MPH | 10 KPH

TIRE LOAD LIMITS AT VARIOUS COLD INFLATION PRESSURES

	33	36	40	44	47	51	54	58	62	65	69
PSI	33	36	40	44	47	51	54	58	62	65	69
KPA	225	250	275	300	325	350	375	400	425	450	475
LBS	17,600	18,700	19,800	20,900	22,000	23,400	24,000	24,700	26,000	26,800	27,600
KG	8,000	8,500	9,000	9,500	10,000	10,600	10,900	11,200	11,800	12,150	12,500
	16 PLY			20 PLY				24 PLY			



26.5 - 25 TUBELESS

	PLY RATING	TRA / APPLICATION	SPEC	ARTICLE #	APPROXIMATE INFLATED DIMENSIONS					MINIMUM DUAL SPACING [INCH]	RECOMMENDED RIM / FLANGE HEIGHT [INCH]
					OD [INCH / MM]	OW [INCH / MM]	SLR [INCH / MM]	SLW [INCH / MM]	OTD [32ND / MM]		
PTLD	26	L-5S	-	417335	71.1 1,806	27.0 686	32.3 820	30.5 775	108 86.0	-	22.00/3.0
PTLD UMS	32	L-5S	UMS	416568	71.1 1,806	27.0 686	32.3 820	30.5 775	108 86.0	-	22.00/3.0
SDT LD	20	L-5	-	403989	71.1 1,806	27.0 686	32.3 820	30.5 775	108 86.0	-	22.00/3.0
SDT LD	26	L-5	-	416428	71.1 1,806	27.0 686	32.3 820	30.5 775	108 86.0	-	22.00/3.0
SRG	44	IND-3	IDU	480136	68.8 1,747	27.7 704	30.5 775	31.3 795	44 35.0	-	22.00/3.0
SRG LD	20	E-3, L-3	LD	400629	69.2 1,758	26.6 676	30.9 785	30.0 762	44 35.0	-	22.00/3.0
SRG	26	E-3, L-3	-	401757	69.2 1,758	26.6 676	30.9 785	30.0 762	44 35.0	-	22.00/3.0
SRG DT LD	26	L-4	-	416401	71.1 1,806	26.9 683	32.1 815	30.4 772	67 53.0	-	22.00/3.0

EARTHMOVER - SRG LD

MAX SPEED 30 MPH | 50 KPH

TIRE LOAD LIMITS AT VARIOUS COLD INFLATION PRESSURES

	33 KPA	36 KPA	40 KPA	44 KPA	47 KPA
PSI	225	250	275	300	325
LBS	17,100	18,200	19,300	20,400	20,900
KG	7,750	8,250	8,750	9,250	9,500
	20 PLY				26 PLY

INDUSTRIAL - SRG - LOAD WHEEL

TIRE LOAD LIMITS AT VARIOUS COLD INFLATION PRESSURES

	STATIC		CREEP		CREEP		CREEP		CREEP	
	PSI	KPA	3	5	9	12	15	19	MPH	KM/H
	134	920	0	0	0	0	0	0	0	0
LBS	81,700	72,650	65,850	61,300	59,000	57,650	56,750	56,250	19	30
KG	37,050	32,950	29,850	27,800	26,750	26,150	25,750	25,550		
	44 PLY									

INDUSTRIAL - SRG DT LD - STEERING WHEEL

TIRE LOAD LIMITS AT VARIOUS COLD INFLATION PRESSURES

	STATIC		CREEP		CREEP		CREEP		CREEP	
	PSI	KPA	3	5	9	12	15	19	MPH	KM/H
	134	920	0	0	0	0	0	0	0	0
LBS	65,350	58,100	52,700	49,050	47,200	46,100	45,400	45,000	19	30
KG	29,650	26,350	23,900	22,250	21,400	20,900	20,600	20,450		
	44 PLY									

LOADER - PTLD, PTLD UMS, SDT LD, SRG, SRG DT LD, SRG LD

MAX SPEED 5 MPH | 10 KPH

TIRE LOAD LIMITS AT VARIOUS COLD INFLATION PRESSURES

	33	36	40	44	47	51	54	58	62	65	69	73	76	80
PSI	225	250	275	300	325	350	375	400	425	450	475	500	525	550
LBS	22,000	24,000	25,400	26,800	27,600	29,100	30,000	30,900	32,000	33,100	34,200	35,300	36,400	37,500
KG	10,000	10,900	11,500	12,150	12,500	13,200	13,600	14,000	14,500	15,000	15,500	16,000	16,500	17,000
	20 PLY				26 PLY				32 PLY					

29.5 - 25 TUBELESS

	PLY RATING	TRA / APPLICATION	SPEC	ARTICLE #	APPROXIMATE INFLATED DIMENSIONS					MINIMUM DUAL SPACING [INCH]	RECOMMENDED RIM / FLANGE HEIGHT [INCH]
					OD [INCH / MM]	OW [INCH / MM]	SLR [INCH / MM]	SLW [INCH / MM]	OTD [32ND / MM]		
HTLD	28	L-5S	-	416991	75.6 1,920	29.5 749	33.4 848	31.9 810	120 95.5	-	25.00/3.5
PTLD	34	L-5S	NY	417408	75.6 1,920	29.5 749	33.4 848	31.9 810	120 95.5	-	25.00/3.5
PTLD UMS	34	L-5S	UMS	430484	75.6 1,920	29.5 749	33.4 848	31.9 810	120 95.5	-	25.00/3.5
SAND CHAMPION	28	E-7	NY	416908	71.9 1,826	30.3 770.0	30.9 785.0	-	22 17.5	-	25.00/3.5
SDT LD	22	L-5	-	413984	74.9 1,902	29.9 759	33.4 848	33.8 859	120 95.5	-	25.00/3.5
SDT LD	28	L-5	-	416436	74.9 1,902	29.9 759	33.4 848	33.8 859	120 95.5	-	25.00/3.5
SGG	22	E-2, L-2	LD	404810	74.3 1,887	30.3 770	33.2 843	33.7 856	47 37.5	-	25.00/3.5
SRG LD	28	E-3, L-3	LD	414638	74.0 1,880	30.8 782	32.6 828	34.9 886	48 38.0	-	25.00/3.5
SRG DT LD	28	L-4	-	416924	75.6 1,920	29.5 749	33.4 848	31.9 810	77 61.0	-	25.00/3.5

EARTHMOVER - SGG, SRG LD

MAX SPEED 30 MPH | 50 KPH

TIRE LOAD LIMITS AT VARIOUS COLD INFLATION PRESSURES

PSI	33	36	40	44	47
KPA	225	250	275	300	325
LBS	20,400	22,000	23,400	24,000	25,400
KG	9,250	10,000	10,600	10,900	11,500
	22 PLY				28 PLY

FLOTATION - SAND CHAMPION

MAX SPEED 40 MPH | 65 KPH

TIRE LOAD LIMITS AT VARIOUS COLD INFLATION PRESSURES

PSI	10	13	16	19	22	25	28	30	33	36
KPA	70	90	110	130	150	170	190	210	230	250
LBS	9,100	9,900	11,000	11,700	12,800	13,600	14,300	15,200	16,100	17,100
KG	4,125	4,500	5,000	5,300	5,800	6,150	6,500	6,900	7,300	7,750
	28 PLY									

FLOTATION - SAND CHAMPION

MAX SPEED 30 MPH | 50 KPH

TIRE LOAD LIMITS AT VARIOUS COLD INFLATION PRESSURES

PSI	10	13	16	19	22	25	28	30	33	36
KPA	70	90	110	130	150	170	190	210	230	250
LBS	11,000	12,000	13,200	14,300	15,200	16,500	17,600	18,200	19,300	20,400
KG	5,000	5,450	6,000	6,500	6,900	7,500	8,000	8,250	8,750	9,250
	28 PLY									

FLOTATION - SAND CHAMPION

MAX SPEED 5 MPH | 10 KPH

TIRE LOAD LIMITS AT VARIOUS COLD INFLATION PRESSURES

PSI	10	13	16	19	22	25	28	30	33	36
KPA	70	90	110	130	150	170	190	210	230	250
LBS	14,300	15,700	17,100	18,700	20,400	21,500	22,700	24,000	25,400	26,800
KG	6,500	7,100	7,750	8,500	9,250	9,750	10,300	10,900	11,500	12,150
	28 PLY									

LOADER - HTLD, PTLD, PTLD UMS, SDT LD, SGG, SRG DT LD, SRG LD

MAX SPEED 5 MPH | 10 KPH

TIRE LOAD LIMITS AT VARIOUS COLD INFLATION PRESSURES

PSI	33	36	40	44	47	51	54	58	62	65	69	73	76
KPA	225	250	275	300	325	350	375	400	425	450	475	500	525
LBS	26,800	28,300	30,000	32,000	33,100	35,300	36,400	37,500	38,600	40,800	41,900	43,000	44,100
KG	12,150	12,850	13,600	14,500	15,000	16,000	16,500	17,000	17,500	18,500	19,000	19,500	20,000
	22 PLY				28 PLY				34 PLY				



370 / 75 - 28

PLY RATING	TRA / APPLICATION	SPEC	ARTICLE #	APPROXIMATE INFLATED DIMENSIONS					MINIMUM DUAL SPACING [INCH]	RECOMMENDED RIM / FLANGE HEIGHT [INCH]	
				OD [INCH / MM]	OW [INCH / MM]	SLR [INCH / MM]	SLW [INCH / MM]	OTD [32ND / MM]			
DURAFORCE MH	14	L-3	MH	429770	50.3 1,278	14.5 368	22.9 582	14.7 373	42 33.3	- -	11.00GR

LOADER - DURAFORCE MH

MAX SPEED 5 MPH | 10 KPH

TIRE LOAD LIMITS AT VARIOUS COLD INFLATION PRESSURES

PSI	65	69	73
KPA	450	475	500
LBS	11,400	11,700	12,000
KG	5,150	5,300	5,450

14 PLY

400 / 75 - 28

PLY RATING	TRA / APPLICATION	SPEC	ARTICLE #	APPROXIMATE INFLATED DIMENSIONS					MINIMUM DUAL SPACING [INCH]	RECOMMENDED RIM / FLANGE HEIGHT [INCH]	
				OD [INCH / MM]	OW [INCH / MM]	SLR [INCH / MM]	SLW [INCH / MM]	OTD [32ND / MM]			
DURAFORCE MH	16	L-3	MH	431453	52.3 1,328	15.7 399	23.8 605	17.8 452	42 33.3	- -	12.00GR

LOADER - DURAFORCE MH

MAX SPEED 5 MPH | 10 KPH

TIRE LOAD LIMITS AT VARIOUS COLD INFLATION PRESSURES

PSI	69	73	76
KPA	475	500	525
LBS	13,600	13,900	14,300
KG	6,150	6,300	6,500

16 PLY

29.5 - 29 TUBELESS

	PLY RATING	TRA / APPLICATION	SPEC	ARTICLE #	APPROXIMATE INFLATED DIMENSIONS					MINIMUM DUAL SPACING [INCH]	RECOMMENDED RIM / FLANGE HEIGHT [INCH]
					OD [INCH / MM]	OW [INCH / MM]	SLR [INCH / MM]	SLW [INCH / MM]	OTD [32ND / MM]		
PTLD UMS	34	L-5S	UMS CRC	431776	80.1 2,034	30.5 775	36.3 922	34.5 876	120 95.5	-	25.00/3.5
SDT LD	28	L-5	-	403962	80.1 2,034	30.5 775	36.3 922	34.5 876	120 95.5	-	25.00/3.5
SRG	28	E-3	-	401889	78.0 1,981	30.8 782	34.6 879	34.9 886	48 38.0	-	25.00/3.5
SRG	34	E-3	-	401625	78.0 1,981	30.8 782	34.6 879	34.9 886	48 38.0	-	25.00/3.5
SRG LD	40	L-3	LD	416916	78.0 1,981	30.8 782	34.6 879	34.9 886	48 38.0	-	25.00/3.5

EARTHMOVER - SRG

MAX SPEED 30 MPH | 50 KPH

TIRE LOAD LIMITS AT VARIOUS COLD INFLATION PRESSURES

	33 KPA	36 250	40 275	44 300	47 325	51 350	54 375	58 400
LBS	22,000	23,400	24,700	26,000	26,800	28,300	29,100	30,900
KG	10,000	10,600	11,200	11,800	12,150	12,850	13,200	14,000
	28 PLY				34 PLY			

LOADER - PTLD UMS, SDT LD, SRG, SRG LD

MAX SPEED 5 MPH | 10 KPH

TIRE LOAD LIMITS AT VARIOUS COLD INFLATION PRESSURES

	33	36	40	44	47	51	54	58	62	65	69	73	76	80	83	87	91
LBS	28,300	30,900	32,000	34,200	35,300	37,500	38,600	39,700	41,900	43,000	44,100	45,400	46,700	48,100	49,400	50,700	52,000
KG	12,850	14,000	14,500	15,500	16,000	17,000	17,500	18,000	19,000	19,500	20,000	20,600	21,200	21,800	22,400	23,000	23,600
	28 PLY								34 PLY				40 PLY				

33.25 - 29 TUBELESS

	PLY RATING	TRA / APPLICATION	SPEC	ARTICLE #	APPROXIMATE INFLATED DIMENSIONS					MINIMUM DUAL SPACING [INCH]	RECOMMENDED RIM / FLANGE HEIGHT [INCH]
					OD [INCH / MM]	OW [INCH / MM]	SLR [INCH / MM]	SLW [INCH / MM]	OTD [32ND / MM]		
SRG	32	E-3	-	280138	82.3 2,090	33.9 861	36.9 937	38.5 978	57 45.0	-	27.00/3.5

EARTHMOVER - SRG

MAX SPEED 30 MPH | 50 KPH

TIRE LOAD LIMITS AT VARIOUS COLD INFLATION PRESSURES

	33 KPA	36 250	40 275	44 300	47 325
LBS	26,800	28,300	30,000	30,900	33,100
KG	12,150	12,850	13,600	14,000	15,000
	32 PL				



18.00 - 33 TUBELESS

	PLY RATING	TRA / APPLICATION	SPEC	ARTICLE #	APPROXIMATE INFLATED DIMENSIONS					MINIMUM DUAL SPACING [INCH]	RECOMMENDED RIM / FLANGE HEIGHT [INCH]
					OD [INCH / MM]	OW [INCH / MM]	SLR [INCH / MM]	SLW [INCH / MM]	OTD [32ND / MM]		
SRG DT	32	E-4	-	413925	72.9 1,852	20.3 516	34.1 866	22.6 574	69 55.0	23.1 587	13.00/2.5
SRG DT	32	E-4	CRC	414972	72.9 1,852	20.3 516	34.1 866	22.6 574	69 55.0	23.1 587	13.00/2.5
SRG DT	44	IND-4	IDU	421308	72.9 1,852	20.3 516	34.1 866	22.6 574	69 55.0	23.1 587	13.00/2.5

EARTHMOVER - SRG DT

MAX SPEED 30 MPH | 50 KPH

TIRE LOAD LIMITS AT VARIOUS COLD INFLATION PRESSURES

PSI	40	44	47	51	54	58	62	65	69	73	76	80	83
KPA	275	300	325	350	375	400	425	450	475	500	525	550	575
LBS	14,300	15,200	16,100	16,500	17,600	18,200	18,700	19,300	19,800	20,400	20,900	22,000	22,700
KG	6,500	6,900	7,300	7,500	8,000	8,250	8,500	8,750	9,000	9,250	9,500	10,000	10,300

32 PLY

INDUSTRIAL - SRG DT - LOAD WHEEL

TIRE LOAD LIMITS AT VARIOUS COLD INFLATION PRESSURES

PSI	145												
KPA	1,000												
MPH	STATIC	CREEP		3	5	9	12	15	19				
	0	CREEP		5	10	15	20	25	30				
LBS	84,050	74,700		67,700	63,050	60,700	59,300	58,400	57,900				
	38,100	33,900		30,700	28,600	27,550	26,900	26,500	26,250				

44 PLY

INDUSTRIAL - SRG DT - STEERING WHEEL

TIRE LOAD LIMITS AT VARIOUS COLD INFLATION PRESSURES

PSI	145												
KPA	1,000												
MPH	STATIC	CREEP		3	5	9	12	15	19				
	0	CREEP		5	10	15	20	25	30				
LBS	67,250	59,750		54,150	50,450	48,550	47,450	46,700	46,300				
	30,500	27,100		24,550	22,900	22,050	21,500	21,200	21,000				

44 PLY

30.00 - 33 TUBELESS

	PLY RATING	TRA / APPLICATION	SPEC	ARTICLE #	APPROXIMATE INFLATED DIMENSIONS					MINIMUM DUAL SPACING [INCH]	RECOMMENDED RIM / FLANGE HEIGHT [INCH]
					OD [INCH / MM]	OW [INCH / MM]	SLR [INCH / MM]	SLW [INCH / MM]	OTD [32ND / MM]		
SRG DT LD	46	IND-4	IDU	416215	74.7 1,897	29.1 739	34.5 876	32.9 836	67 53.0	- -	26.00/1.5

INDUSTRIAL - SRG DT LD - LOAD WHEEL

TIRE LOAD LIMITS AT VARIOUS COLD INFLATION PRESSURES

PSI	122									
KPA	840									
MPH KM/H	STATIC	CREEP	3	5	9	12	15	19		
	0	CREEP	5	10	15	20	25	30		
LBS KG	86,600	76,950	69,750	64,950	62,550	61,100	60,150	59,600		
	39,300	34,900	31,650	29,450	28,350	27,700	27,300	27,050		

46

INDUSTRIAL - SRG DT LD - STEERING WHEEL

TIRE LOAD LIMITS AT VARIOUS COLD INFLATION PRESSURES

PSI	134									
KPA	920									
MPH KM/H	STATIC	CREEP	3	5	9	12	15	19		
	0	CREEP	5	10	15	20	25	30		
LBS KG	69,300	61,550	55,800	51,950	50,050	48,900	48,100	47,700		
	31,450	27,900	25,300	23,550	22,700	22,150	21,850	21,650		

46

33.5 - 33 TUBELESS

	PLY RATING	TRA / APPLICATION	SPEC	ARTICLE #	APPROXIMATE INFLATED DIMENSIONS					MINIMUM DUAL SPACING [INCH]	RECOMMENDED RIM / FLANGE HEIGHT [INCH]
					OD [INCH / MM]	OW [INCH / MM]	SLR [INCH / MM]	SLW [INCH / MM]	OTD [32ND / MM]		
SRG DT	50	IND-4	IDU	800560	90.4 2,296	33.5 851	41.0 1,041	38.8 986	86 68.5	- -	28.00/4.0

INDUSTRIAL - SRG DT - LOAD WHEEL

TIRE LOAD LIMITS AT VARIOUS COLD INFLATION PRESSURES

PSI	118									
KPA	810									
MPH KM/H	STATIC	CREEP	3	5	9	12	15	19		
	0	CREEP	5	10	15	20	25	30		
LBS KG	133,200	118,400	107,300	99,900	96,200	94,000	92,500	91,700		
	60,450	53,700	48,700	45,300	43,650	42,650	41,950	41,600		

50

INDUSTRIAL - SRG - STEERING WHEEL

TIRE LOAD LIMITS AT VARIOUS COLD INFLATION PRESSURES

PSI	118									
KPA	810									
MPH KM/H	STATIC	CREEP	3	5	9	12	15	19		
	0	CREEP	5	10	15	20	25	30		
LBS KG	106,550	94,700	85,850	79,900	76,950	75,200	74,000	73,350		
	48,350	42,950	38,950	36,250	34,900	34,100	33,550	33,300		

50



65 / 35 - 33 TUBELESS

	PLY RATING	TRA / APPLICATION	SPEC	ARTICLE #	APPROXIMATE INFLATED DIMENSIONS					MINIMUM DUAL SPACING [INCH]	RECOMMENDED RIM / FLANGE HEIGHT [INCH]
					OD [INCH / MM]	OW [INCH / MM]	SLR [INCH / MM]	SLW [INCH / MM]	OTD [32ND / MM]		
HTLD	42	L-5/L-5S	NS	430246	82.8 2,103	33.8 859	38.3 973	38.2 970	120 95.0	- -	28.00/3.5
PTLD	36	L-5S	NY	417602	82.8 2,103	33.8 859	38.3 973	38.2 970	120 95.0	- -	28.00/3.5
PTLD	42	L-5S	NS	427917	82.8 2,103	33.8 859	38.3 973	38.2 970	120 95.0	- -	28.00/3.5
SDT LD	30	L-5	NY	416649	82.8 2,103	33.8 859	38.3 973	37.5 952	120 95.0	- -	28.00/3.5
SDT LD	42	L-5	NS	427832	82.8 2,103	33.8 859	38.3 973	37.5 952	120 95.0	- -	28.00/3.5
SRG DT LD	30	L-4	NY	416185	82.8 2,103	34.7 881	38.2 970	38.2 970	72 57.0	- -	22.00/3.0
SRG DT LD	42	IND-4	IDU	421294	82.8 2,103	34.7 881	38.2 970	38.2 970	72 57.0	- -	22.00/3.0

LOADER - HTLD, PTLD, SDT LD, SRG DT LD

MAX SPEED 5 MPH | 10 KPH

TIRE LOAD LIMITS AT VARIOUS COLD INFLATION PRESSURES

	40 275	44 300	47 325	51 350	54 375	58 400	62 425	65 450	69 475	73 500	76 525	80 550	83 575	87 600	91 625
PSI															
KPA															
LBS	36,400	37,500	39,700	41,900	43,000	44,100	46,700	48,100	49,400	50,700	52,000	53,600	55,100	56,800	58,400
KG	16,500	17,000	18,000	19,000	19,500	20,000	21,200	21,800	22,400	23,000	23,600	24,300	25,000	25,750	26,500
	30 PLY										36 PLY			42 PLY	

INDUSTRIAL - SRG DT LD - LOAD WHEEL

TIRE LOAD LIMITS AT VARIOUS COLD INFLATION PRESSURES

PSI	109															
KPA	750															
MPH	STATIC		CREEP		3		5		9		12		15		19	
KM/H	0		CREEP		5		10		15		20		25		30	
LBS	105,100		93,450		84,700		78,850		75,900		74,150		73,000		72,400	
KG	47,700		42,400		38,400		35,750		34,450		33,650		33,100		32,850	
	42 PLY															

INDUSTRIAL - SRG DT LD - STEERING WHEEL

TIRE LOAD LIMITS AT VARIOUS COLD INFLATION PRESSURES

PSI	109															
KPA	750															
MPH	STATIC		CREEP		3		5		9		12		15		19	
KM/H	0		CREEP		5		10		15		20		25		30	
LBS	84,100		74,750		67,750		63,100		60,700		59,300		58,400		57,900	
KG	38,150		33,900		30,700		28,600		27,550		26,900		26,500		26,300	
	42 PLY															

35 / 65 - 33 TUBELESS

	PLY RATING	TRA / APPLICATION	SPEC	ARTICLE #	APPROXIMATE INFLATED DIMENSIONS					MINIMUM DUAL SPACING [INCH]	RECOMMENDED RIM / FLANGE HEIGHT [INCH]
					OD [INCH / MM]	OW [INCH / MM]	SLR [INCH / MM]	SLW [INCH / MM]	OTD [32ND / MM]		
DURALOAD DT	42	L-4	NY	000989	82.8 2,103	36.6 930	38.4 975	37.8 960	72 57	-	28.00/3.5
DURALOAD DT	42	L-4	NS	000990	82.8 2,103	36.6 930	38.4 975	37.8 960	72 57	-	28.00/3.5
DURALOAD PT	42	L-5S	NY	000992	81.9 2,080	36.3 922	38.3 973	37.8 960	116 92	-	28.00/3.5
DURALOAD SDT	42	L-5	NY	000991	81.9 2,080	36.3 922	38.3 973	37.8 960	116 92	-	28.00/3.5
DURALOAD SDT	42	L-5	NS	431657	81.9 2,080	36.3 922	38.3 973	37.8 960	116 92	-	28.00/3.5

LOADER - DURALOAD DT, DURALOAD PT, DURALOAD SDT

MAX SPEED 5 MPH | 10 KPH

TIRE LOAD LIMITS AT VARIOUS COLD INFLATION PRESSURES

PSI	40	44	47	51	54	58	62	65	69	73	76	80	83	87	91
KPA	275	300	325	350	375	400	425	450	475	500	525	550	575	600	625
LBS	36,400	37,500	39,700	41,900	43,000	44,100	46,700	48,100	49,400	50,700	52,000	53,600	55,100	56,800	58,400
KG	16,500	17,000	18,000	19,000	19,500	20,000	21,200	21,800	22,400	23,000	23,600	24,300	25,000	25,750	26,500

42 PLY

21.00 - 35 TUBELESS

	PLY RATING	TRA / APPLICATION	SPEC	ARTICLE #	APPROXIMATE INFLATED DIMENSIONS					MINIMUM DUAL SPACING [INCH]	RECOMMENDED RIM / FLANGE HEIGHT [INCH]
					OD [INCH / MM]	OW [INCH / MM]	SLR [INCH / MM]	SLW [INCH / MM]	OTD [32ND / MM]		
SRG DT	36	E-4	CRC	414131	80.1 2,034	22.9 582	37.1 942	26.3 668	67 53.0	27.6 701	15.00/3.0
SRG DT	40	IND-4	IDU	411604	80.1 2,034	22.9 582	37.1 942	26.3 668	67 53.0	27.6 701	15.00/3.0

EARTHMOVER - SRG DT

MAX SPEED 30 MPH | 50 KPH

TIRE LOAD LIMITS AT VARIOUS COLD INFLATION PRESSURES

PSI	40	44	47	51	54	58	62	65	69	73	76	80
KPA	275	300	325	350	375	400	425	450	475	500	525	550
LBS	19,300	20,400	20,900	22,000	22,700	24,000	24,700	25,400	26,000	26,800	28,300	28,300
KG	8,750	9,250	9,500	10,000	10,300	10,900	11,200	11,500	11,800	12,150	12,850	12,850

36 PLY

INDUSTRIAL - SRG DT - LOAD WHEEL

TIRE LOAD LIMITS AT VARIOUS COLD INFLATION PRESSURES

PSI	145											
KPA	1,000											
MPH	STATIC		CREEP		3	5	9	12	15	19		
KM/H	0		CREEP		5	10	15	20	25	30		
LBS	96,500		85,500		78,500	71,500	69,500	68,000	66,000	66,000		
KG	43,750		38,750		35,500	32,500	31,500	30,750	30,000	30,000		

40 PLY

INDUSTRIAL - SRG DT - STEERING WHEEL

TIRE LOAD LIMITS AT VARIOUS COLD INFLATION PRESSURES

PSI	145											
KPA	1,000											
MPH	STATIC		CREEP		3	5	9	12	15	19		
KM/H	0		CREEP		5	10	15	20	25	30		
LBS	76,000		68,000		61,500	58,400	55,100	55,100	53,600	53,600		
KG	34,500		30,750		28,000	26,500	25,000	25,000	24,300	24,300		

40 PLY



29.5 - 35 TUBELESS

	PLY RATING	TRA / APPLICATION	SPEC	ARTICLE #	APPROXIMATE INFLATED DIMENSIONS					MINIMUM DUAL SPACING [INCH]	RECOMMENDED RIM / FLANGE HEIGHT [INCH]
					OD [INCH / MM]	OW [INCH / MM]	SLR [INCH / MM]	SLW [INCH / MM]	OTD [32ND / MM]		
SRG	34	E-3	-	401668	83.4 2,118	30.5 775	37.0 940	34.6 879	48 38.0	- -	25.00/3.5

EARTHMOVER - SRG

MAX SPEED 30 MPH | 50 KPH

TIRE LOAD LIMITS AT VARIOUS COLD INFLATION PRESSURES

	40 KPA	44 300	47 325	51 350	54 375	58 400
PSI	40	44	47	51	54	58
LBS	26,800	28,300	30,000	30,900	32,000	33,100
KG	12,150	12,850	13,600	14,000	14,500	15,000

34 PLY

33.25 - 35 TUBELESS

	PLY RATING	TRA / APPLICATION	SPEC	ARTICLE #	APPROXIMATE INFLATED DIMENSIONS					MINIMUM DUAL SPACING [INCH]	RECOMMENDED RIM / FLANGE HEIGHT [INCH]
					OD [INCH / MM]	OW [INCH / MM]	SLR [INCH / MM]	SLW [INCH / MM]	OTD [32ND / MM]		
PTLD	50	IND-3S	IDU	003565	89.6 2,276	34.1 886	40.5 1,029	35.4 899	53 42.0	- -	27.00/3.5
SRG	38	E-3	-	410241	89.7 2,278	33.7 856	38.9 988	38.1 968	53 42.0	- -	27.00/3.5
SRG DT	38	E-4	-	413380	89.2 2,266	34.0 864	40.1 1,019	38.2 970	86 68.5	- -	27.00/3.5
SRG DT	50	IND-4	IDU	280004	82.9 2,266	34.0 864	40.1 1,019	38.2 970	86 68.5	- -	27.00/3.5

EARTHMOVER - SRG, SRG DT

MAX SPEED 30 MPH | 50 KPH

TIRE LOAD LIMITS AT VARIOUS COLD INFLATION PRESSURES

	40 KPA	44 300	47 325	51 350	54 375	58 400
PSI	40	44	47	51	54	58
LBS	32,000	34,200	35,300	37,500	38,600	39,700
KG	14,500	15,500	16,000	17,000	17,500	18,000

38 PLY

INDUSTRIAL - PTLD, SRG DT - LOAD WHEEL

TIRE LOAD LIMITS AT VARIOUS COLD INFLATION PRESSURES

MPH KM/H	STATIC	CREEP	3	5	9	12	15	19
	0	CREEP	5	10	15	20	25	30
LBS	133,200	118,400	107,300	99,900	96,200	94,000	92,500	91,700
KG	60,450	53,700	48,700	45,300	43,650	42,650	41,950	41,600

50 PLY

INDUSTRIAL - PTLD, SRG DT - STEERING WHEEL

TIRE LOAD LIMITS AT VARIOUS COLD INFLATION PRESSURES

MPH KM/H	STATIC	CREEP	3	5	9	12	15	19
	0	CREEP	5	10	15	20	25	30
LBS	106,550	94,700	85,850	79,900	76,950	75,200	74,000	73,350
KG	48,350	42,950	38,950	36,250	34,900	34,100	33,550	33,300

50 PLY

37.25 - 35 TUBELESS

	PLY RATING	TRA / APPLICATION	SPEC	ARTICLE #	APPROXIMATE INFLATED DIMENSIONS					MINIMUM DUAL SPACING [INCH]	RECOMMENDED RIM / FLANGE HEIGHT [INCH]
					OD [INCH / MM]	OW [INCH / MM]	SLR [INCH / MM]	SLW [INCH / MM]	OTD [32ND / MM]		
SRG / SRG LD	36	E-3	-	413461	94.7 2,405	37.9 963	41.9 1,064	42.0 1,067	62 49.0	-	31.00/4.0

EARTHMOVER - SRG, SRG LD

MAX SPEED 30 MPH | 50 KPH

TIRE LOAD LIMITS AT VARIOUS COLD INFLATION PRESSURES

PSI	40	44	47
KPA	275	300	325
LBS	38,600	40,800	43,000
KG	17,500	18,500	19,500

36 PLY

37.5 - 39 TUBELESS

	PLY RATING	TRA / APPLICATION	SPEC	ARTICLE #	APPROXIMATE INFLATED DIMENSIONS					MINIMUM DUAL SPACING [INCH]	RECOMMENDED RIM / FLANGE HEIGHT [INCH]
					OD [INCH / MM]	OW [INCH / MM]	SLR [INCH / MM]	SLW [INCH / MM]	OTD [32ND / MM]		
SRG	52	E-3	-	412546	99.5 2,527	38.0 965	44.8 1,138	43.0 1,092	60 47.5	-	32.00/4.5

EARTHMOVER - SRG

MAX SPEED 30 MPH | 50 KPH

TIRE LOAD LIMITS AT VARIOUS COLD INFLATION PRESSURES

PSI	33	36	40	44	47	51	54	58	62	65	69
KPA	225	250	275	300	325	350	375	400	425	450	475
LBS	37,500	40,800	43,000	45,400	46,700	49,400	50,700	53,600	55,100	56,800	58,400
KG	17,000	18,500	19,500	20,600	21,200	22,400	23,000	24,300	25,000	25,750	26,500

52 PLY

41.25 / 70 - 39 TUBELESS

	PLY RATING	TRA / APPLICATION	SPEC	ARTICLE #	APPROXIMATE INFLATED DIMENSIONS					MINIMUM DUAL SPACING [INCH]	RECOMMENDED RIM / FLANGE HEIGHT [INCH]
					OD [INCH / MM]	OW [INCH / MM]	SLR [INCH / MM]	SLW [INCH / MM]	OTD [32ND / MM]		
SDT LD	42	L-5	NY	417033	98.7 2,507	40.9 1,039	45.1 1,146	43.8 1,112	146 116.0	-	32.00/4.5
SDT LD	42	L-5	NS	416789	98.7 2,507	40.9 1,039	45.1 1,146	43.8 1,112	146 116.0	-	32.00/4.5

LOADER - SDT LD

MAX SPEED 5 MPH | 10 KPH

TIRE LOAD LIMITS AT VARIOUS COLD INFLATION PRESSURES

PSI	40	44	47	51	54	58	62	65	69
KPA	275	300	325	350	375	400	425	450	475
LBS	60,000	64,000	66,000	69,500	71,500	74,000	78,500	80,500	82,500
KG	27,250	29,000	30,000	31,500	32,500	33,500	35,500	36,500	37,500

42 PLY



65 / 40 - 39 TUBELESS

	PLY RATING	TRA / APPLICATION	SPEC	ARTICLE #	APPROXIMATE INFLATED DIMENSIONS					MINIMUM DUAL SPACING [INCH]	RECOMMENDED RIM / FLANGE HEIGHT [INCH]
					OD [INCH / MM]	OW [INCH / MM]	SLR [INCH / MM]	SLW [INCH / MM]	OTD [32ND / MM]		
SDT LD	36	L-5	-	280159	94.9 2,410	38.6 980	43.3 1,100	42.8 1,087	134 106.5	- -	32.00/4.5

LOADER - SDT LD

MAX SPEED 5 MPH | 10 KPH

TIRE LOAD LIMITS AT VARIOUS COLD INFLATION PRESSURES

	40	44	47	51	54	58	62	65	69
PSI	40	44	47	51	54	58	62	65	69
KPA	275	300	325	350	375	400	425	450	475
LBS	49,000	52,000	55,100	56,800	60,000	61,500	64,000	66,000	68,000
KG	22,400	23,600	25,000	25,750	27,250	28,000	29,000	30,000	30,750

36 PLY

45 / 65 - 39 TUBELESS

	PLY RATING	TRA / APPLICATION	SPEC	ARTICLE #	APPROXIMATE INFLATED DIMENSIONS					MINIMUM DUAL SPACING [INCH]	RECOMMENDED RIM / FLANGE HEIGHT [INCH]
					OD [INCH / MM]	OW [INCH / MM]	SLR [INCH / MM]	SLW [INCH / MM]	OTD [32ND / MM]		
PTLD	46	L-5S	NS	423173	103.5 2,629	38.6 980	43.3 1,100	43.6 1,107	147 116.5	- -	32.00/4.0

LOADER - PTLD

MAX SPEED 5 MPH | 10 KPH

TIRE LOAD LIMITS AT VARIOUS COLD INFLATION PRESSURES

	40	44	47	51	54	58	62	65	69	73	76
PSI	40	44	47	51	54	58	62	65	69	73	76
KPA	275	300	325	350	375	400	425	450	475	500	525
LBS	61,500	64,000	68,000	71,500	74,000	76,000	80,500	82,500	85,500	88,000	91,000
KG	28,000	29,000	30,750	32,500	33,500	34,500	36,500	37,500	38,750	40,000	41,250

46 PLY

45 / 65 - 45 TUBELESS

	PLY RATING	TRA / APPLICATION	SPEC	ARTICLE #	APPROXIMATE INFLATED DIMENSIONS					MINIMUM DUAL SPACING [INCH]	RECOMMENDED RIM / FLANGE HEIGHT [INCH]
					OD [INCH / MM]	OW [INCH / MM]	SLR [INCH / MM]	SLW [INCH / MM]	OTD [32ND / MM]		
DURALOAD DT	58	L-4	NY	431691	109.3 2,776	45.6 1,158	50.0 1,270	47.5 1,207	76 60.0	- -	36.00/4.5
DURALOAD DT	58	L-4	NS	431708	109.3 2,776	45.6 1,158	50.0 1,270	47.5 1,207	76 60.0	- -	36.00/4.5
DURALOAD PT	58	L-5S	NY	000468	109.0 2,769	45.6 1,158	50.0 1,270	47.3 1,201	133 106.0	- -	36.00/4.5
DURALOAD PT	58	L-5S	NS	000469	109.0 2,769	45.6 1,158	50.0 1,270	47.3 1,201	133 106.0	- -	36.00/4.5
DURALOAD SDT	58	L-5	NY	431674	109.0 2,769	45.6 1,158	50.0 1,270	47.3 1,201	130 103.0	- -	36.00/4.5
DURALOAD SDT	58	L-5	NS	431606	109.0 2,769	45.6 1,158	50.0 1,270	47.3 1,201	130 103.0	- -	36.00/4.5

LOADER - DURALOAD DT, DURALOAD PT, DURALOAD SDT

MAX SPEED 5 MPH | 10 KPH

TIRE LOAD LIMITS AT VARIOUS COLD INFLATION PRESSURES

PSI	40	44	47	51	54	58	62	65	69	73	76	80	83	87	91	94	98
KPA	275	300	325	350	375	400	425	450	475	500	525	550	575	600	625	650	675
LBS	66,000	69,500	71,500	76,000	78,500	82,500	85,500	88,000	91,000	93,500	96,500	99,000	102,000	104,200	106,400	108,600	110,000
KG	30,000	31,500	32,500	34,500	35,500	37,500	38,750	40,000	41,250	42,500	43,750	45,000	46,250	47,250	48,250	49,250	50,000

58 PLY

65 / 45 - 45 TUBELESS

	PLY RATING	TRA / APPLICATION	SPEC	ARTICLE #	APPROXIMATE INFLATED DIMENSIONS					MINIMUM DUAL SPACING [INCH]	RECOMMENDED RIM / FLANGE HEIGHT [INCH]
					OD [INCH / MM]	OW [INCH / MM]	SLR [INCH / MM]	SLW [INCH / MM]	OTD [32ND / MM]		
HTLD	50	L-5/L-5S	NY	280255	108.1 2,746	43.1 1,095	49.4 1,255	48.7 1,237	150 119.0	- -	36.00/4.5

LOADER - HTLD

MAX SPEED 5 MPH | 10 KPH

TIRE LOAD LIMITS AT VARIOUS COLD INFLATION PRESSURES

PSI	40	44	47	51	54	58	62	65	69	73	76	80	83
KPA	275	300	325	350	375	400	425	450	475	500	525	550	575
LBS	66,000	69,500	71,500	76,000	78,500	82,500	85,500	88,000	91,000	93,500	96,500	99,000	102,000
KG	30,000	31,500	32,500	34,500	35,500	37,500	38,750	40,000	41,250	42,500	43,750	45,000	46,250

50 PLY



18.00 - 49 TUBELESS

	PLY RATING	TRA / APPLICATION	SPEC	ARTICLE #	APPROXIMATE INFLATED DIMENSIONS					MINIMUM DUAL SPACING [INCH]	RECOMMENDED RIM / FLANGE HEIGHT [INCH]
					OD [INCH / MM]	OW [INCH / MM]	SLR [INCH / MM]	SLW [INCH / MM]	OTD [32ND / MM]		
SRG	32	E-3	-	401560	87.0 2,210	19.4 493	40.6 1,031	20.9 531	34 27,0	24.2 615	13.00/2.5

EARTHMOVER - SRG

MAX SPEED 30 MPH | 50 KPH

TIRE LOAD LIMITS AT VARIOUS COLD INFLATION PRESSURES

	40	44	47	51	54	58	62	65	69	73	76	80	83
PSI	40	44	47	51	54	58	62	65	69	73	76	80	83
KPA	275	300	325	350	375	400	425	450	475	500	525	550	575
LBS	18,200	19,300	20,400	20,900	22,000	22,700	23,400	24,700	25,400	26,000	26,800	27,600	28,300
KG	8,250	8,750	9,250	9,500	10,000	10,300	10,600	11,200	11,500	11,800	12,150	12,500	12,850

32 PLY

27.00 - 49 TUBELESS

	PLY RATING	TRA / APPLICATION	SPEC	ARTICLE #	APPROXIMATE INFLATED DIMENSIONS					MINIMUM DUAL SPACING [INCH]	RECOMMENDED RIM / FLANGE HEIGHT [INCH]
					OD [INCH / MM]	OW [INCH / MM]	SLR [INCH / MM]	SLW [INCH / MM]	OTD [32ND / MM]		
SRG DT	48	E-4	-	411663	105.5 2,680	29.6 752	48.7 1,237	31.4 798	79 62.5	35.1 892	19.50/4.0

EARTHMOVER - SRG

MAX SPEED 30 MPH | 50 KPH

TIRE LOAD LIMITS AT VARIOUS COLD INFLATION PRESSURES

	40	44	47	51	54	58	62	65	69	73	76	80	83
PSI	40	44	47	51	54	58	62	65	69	73	76	80	83
KPA	275	300	325	350	375	400	425	450	475	500	525	550	575
LBS	36,400	37,500	39,700	41,900	43,000	45,400	46,700	48,100	49,400	50,700	52,000	53,600	55,100
KG	16,500	17,000	18,000	19,000	19,500	20,600	21,200	21,800	22,400	23,000	23,600	24,300	25,000

48 PLY

30.00 - 51 TUBELESS

	PLY RATING	TRA / APPLICATION	SPEC	ARTICLE #	APPROXIMATE INFLATED DIMENSIONS					MINIMUM DUAL SPACING [INCH]	RECOMMENDED RIM / FLANGE HEIGHT [INCH]
					OD [INCH / MM]	OW [INCH / MM]	SLR [INCH / MM]	SLW [INCH / MM]	OTD [32ND / MM]		
SRG DT	52	E-4	-	416711	113.0 2,870	33.2 843	52.0 1,321	34.9 886	87 69.0	39.1 993	22.00/4.5

EARTHMOVER - SRG DT

MAX SPEED 30 MPH | 50 KPH

TIRE LOAD LIMITS AT VARIOUS COLD INFLATION PRESSURES

PSI	40	44	47	51	54	58	62	65	69	73	76	80
KPA	275	300	325	350	375	400	425	450	475	500	525	550
LBS	44,100	46,700	49,400	50,700	53,600	55,100	56,800	60,000	61,500	64,000	64,000	66,000
KG	20,000	21,200	22,400	23,000	24,300	25,000	25,750	27,250	28,000	29,000	29,000	30,000

52 PLY

33.00 - 51 TUBELESS

	PLY RATING	TRA / APPLICATION	SPEC	ARTICLE #	APPROXIMATE INFLATED DIMENSIONS					MINIMUM DUAL SPACING [INCH]	RECOMMENDED RIM / FLANGE HEIGHT [INCH]
					OD [INCH / MM]	OW [INCH / MM]	SLR [INCH / MM]	SLW [INCH / MM]	OTD [32ND / MM]		
SRG DT	58	E-4	-	415677	118.3 3,005	36.0 914	54.5 1,384	37.8 960	93 74.0	42.3 1,074	24.00/5.0

EARTHMOVER - SRG DT

MAX SPEED 30 MPH | 50 KPH

TIRE LOAD LIMITS AT VARIOUS COLD INFLATION PRESSURES

PSI	40	44	47	51	54	58	62	65	69	73	76	80	83
KPA	275	300	325	350	375	400	425	450	475	500	525	550	575
LBS	52,000	53,600	56,800	60,000	61,500	64,000	66,000	69,500	71,500	74,000	76,000	78,500	78,500
KG	23,600	24,300	25,750	27,250	28,000	29,000	30,000	31,500	32,500	33,500	34,500	35,500	35,500

58 PLY

36.00 - 51 TUBELESS

	PLY RATING	TRA / APPLICATION	SPEC	ARTICLE #	APPROXIMATE INFLATED DIMENSIONS					MINIMUM DUAL SPACING [INCH]	RECOMMENDED RIM / FLANGE HEIGHT [INCH]
					OD [INCH / MM]	OW [INCH / MM]	SLR [INCH / MM]	SLW [INCH / MM]	OTD [32ND / MM]		
SRG DT	58	E-4	-	414832	126.5 3,213	39.3 998	58.2 1,478	41.1 1,044	104 82.5	46.6 1,184	26.00/5.0

EARTHMOVER - SRG DT

MAX SPEED 30 MPH | 50 KPH

TIRE LOAD LIMITS AT VARIOUS COLD INFLATION PRESSURES

PSI	40	44	47	51	54	58	62	65	69	73	76
KPA	275	300	325	350	375	400	425	450	475	500	525
LBS	61,500	66,000	69,500	71,500	76,000	78,500	80,500	82,500	85,500	88,000	91,000
KG	28,000	30,000	31,500	32,500	34,500	35,500	36,500	37,500	38,750	40,000	41,250

58 PLY



30.00 - 56.5 TUBELESS

	PLY RATING	TRA / APPLICATION	SPEC	ARTICLE #	APPROXIMATE INFLATED DIMENSIONS					MINIMUM DUAL SPACING [INCH]	RECOMMENDED RIM / FLANGE HEIGHT [INCH]
					OD [INCH / MM]	OW [INCH / MM]	SLR [INCH / MM]	SLW [INCH / MM]	OTD [32ND / MM]		
SRG	48	E-3	-	413127	103.4 2,626	28.5 724	47.7 1,212	30.1 765	53 42.0	35.1 892	22.00/1.25

EARTHMOVER - SRG, SRG LD

MAX SPEED 30 MPH | 50 KPH

TIRE LOAD LIMITS AT VARIOUS COLD INFLATION PRESSURES

	40	44	47	51	54	58	62	65	69	73	76	80	83
PSI	40	44	47	51	54	58	62	65	69	73	76	80	83
KPA	275	300	325	350	375	400	425	450	475	500	525	550	575
LBS	36,400	37,500	39,700	41,900	43,000	45,400	46,700	48,100	49,400	50,700	52,000	53,600	55,100
KG	16,500	17,000	18,000	19,000	19,500	20,600	21,200	21,800	22,400	23,000	23,600	24,300	25,000

48 PLY

40.00 - 57 TUBELESS

	PLY RATING	TRA / APPLICATION	SPEC	ARTICLE #	APPROXIMATE INFLATED DIMENSIONS					MINIMUM DUAL SPACING [INCH]	RECOMMENDED RIM / FLANGE HEIGHT [INCH]
					OD [INCH / MM]	OW [INCH / MM]	SLR [INCH / MM]	SLW [INCH / MM]	OTD [32ND / MM]		
SRG DT	76	E-4	NY	424773	142.8 3,627	43.5 1,105	64.9 1,648	46.3 1,176	126 100.0	51.6 1,311	29.00/6.0

EARTHMOVER - SRG DT

MAX SPEED 30 MPH | 50 KPH

TIRE LOAD LIMITS AT VARIOUS COLD INFLATION PRESSURES

	40	44	47	51	54	58	62	65	69	73	76	80	83	87	91
PSI	40	44	47	51	54	58	62	65	69	73	76	80	83	87	91
KPA	275	300	325	350	375	400	425	450	475	500	525	550	575	600	625
LBS	80,500	85,500	88,000	91,000	96,500	99,000	102,000	107,500	110,000	113,500	117,000	120,000	123,500	128,000	128,000
KG	36,500	38,750	40,000	41,250	43,750	45,000	46,250	48,750	50,000	51,500	53,000	54,500	56,000	58,000	58,000

76 PLY

50 / 80 - 57 TUBELESS

	PLY RATING	TRA / APPLICATION	SPEC	ARTICLE #	APPROXIMATE INFLATED DIMENSIONS					MINIMUM DUAL SPACING [INCH]	RECOMMENDED RIM / FLANGE HEIGHT [INCH]
					OD [INCH / MM]	OW [INCH / MM]	SLR [INCH / MM]	SLW [INCH / MM]	OTD [32ND / MM]		
SRG DT LD	68	L-4	NY	421456	142.9 3,630	51.1 1,298	64.1 1,628	54.1 1,374	126 100.0	- -	36.00/6.0

LOADER - SRG DT LD

MAX SPEED 5 MPH | 10 KPH

TIRE LOAD LIMITS AT VARIOUS COLD INFLATION PRESSURES

	33	36	40	44	47	51	54	58	62	65	69	73	76	80	83	87	91
PSI	33	36	40	44	47	51	54	58	62	65	69	73	76	80	83	87	91
KPA	225	250	275	300	325	350	375	400	425	450	475	500	525	550	575	600	625
LBS	107,500	113,500	120,000	128,000	135,500	139,000	147,500	152,000	156,500	161,000	165,500	171,000	176,500	182,000	187,500	193,000	198,500
KG	48,750	51,500	54,500	58,000	61,500	63,000	67,000	69,000	71,000	73,000	75,000	77,500	80,000	82,500	85,000	87,500	90,000

68 PLY

53.5 / 85 - 57 TUBELESS

	PLY RATING	TRA / APPLICATION	SPEC	ARTICLE #	APPROXIMATE INFLATED DIMENSIONS					MINIMUM DUAL SPACING [INCH]	RECOMMENDED RIM / FLANGE HEIGHT [INCH]
					OD [INCH / MM]	OW [INCH / MM]	SLR [INCH / MM]	SLW [INCH / MM]	OTD [32ND / MM]		
SDT LD	76	L-5	NY	420468	151.9 3,858	53.9 1,369	67.7 1,720	58.3 1,481	153 121.5	- -	44.00/6.0

LOADER - SDT LD

MAX SPEED 5 MPH | 10 KPH

TIRE LOAD LIMITS AT VARIOUS COLD INFLATION PRESSURES

PSI	58	62	65	69	73	76	80	83	87	91	94	98	102	105
KPA	400	425	450	475	500	525	550	575	600	625	650	675	700	725
LBS	176,500	182,000	187,500	198,500	204,000	209,000	215,000	220,500	227,000	227,000	233,500	240,500	247,000	253,500
KG	80,000	82,500	85,000	90,000	92,500	95,000	97,500	100,000	103,000	103,000	106,000	109,000	112,000	115,000

76 PLY

58 / 85 - 57 TUBELESS

	PLY RATING	TRA / APPLICATION	SPEC	ARTICLE #	APPROXIMATE INFLATED DIMENSIONS					MINIMUM DUAL SPACING [INCH]	RECOMMENDED RIM / FLANGE HEIGHT [INCH]
					OD [INCH / MM]	OW [INCH / MM]	SLR [INCH / MM]	SLW [INCH / MM]	OTD [32ND / MM]		
SRG DT LD	84	L-4	HRC	430416	154.0 3,912	56.3 1,430	68.5 1,740	60.0 1,524	116 92.0	- -	47.00/6.0
SRG DT LD	84	L-4	NY	424501	154.0 3,912	56.3 1,430	68.5 1,740	60.0 1,524	116 92.0	- -	47.00/6.0

LOADER - SRG DT LD

MAX SPEED 5 MPH | 10 KPH

TIRE LOAD LIMITS AT VARIOUS COLD INFLATION PRESSURES

PSI	58	62	64	69	73	76	80	83	87	91	94	98	102
KPA	400	425	450	475	500	525	550	575	600	625	650	675	700
LBS	198,500	204,000	209,500	215,000	227,000	233,500	233,500	240,500	247,000	253,500	260,000	267,000	275,500
KG	90,000	92,500	95,000	97,500	103,000	106,000	106,000	109,000	112,000	115,000	118,000	121,000	125,000

84 PLY

70 / 70 - 57 TUBELESS

	PLY RATING	TRA / APPLICATION	SPEC	ARTICLE #	APPROXIMATE INFLATED DIMENSIONS					MINIMUM DUAL SPACING [INCH]	RECOMMENDED RIM / FLANGE HEIGHT [INCH]
					OD [INCH / MM]	OW [INCH / MM]	SLR [INCH / MM]	SLW [INCH / MM]	OTD [32ND / MM]		
SDT DT LD	84	L-4	NY	000988	157.2 3,993	67.0 1,702	69.8 1,772	70.4 1,788	116 92.0	- -	60.00/6.0

LOADER - SRG DT LD

MAX SPEED 5 MPH | 10 KPH

TIRE LOAD LIMITS AT VARIOUS COLD INFLATION PRESSURES

PSI	65	69	73	76	80	83	87	91	94	98
KPA	450	475	500	525	550	575	600	625	650	675
LBS	240,500	247,000	253,500	260,000	267,000	275,500	283,500	291,000	291,000	300,000
KG	109,000	112,000	115,000	118,000	121,000	125,000	128,500	132,000	132,000	136,000

84 PLY



COMPACT RADIAL TIRES

320 / 80R18 12.5/80R18*

	LOAD INDEX	TRA / APPLICATION	SPEC	ARTICLE #	APPROXIMATE INFLATED DIMENSIONS					
					RIM WIDTH [INCH / MM]	OD [INCH / MM]	OW [INCH / MM]	SLR [INCH / MM]	ROLLING CIRC [INCH / MM]	OTD [32ND / MM]
RADIAL DURA FORCE RT	141	R-4	-	380497	10.0 254	38.2 970	12.6 320	16.9 429	111.0 2,819	34 27.0

RADIAL DURA FORCE RT **MAX SPEED 5 MPH | 10 KPH**

TIRE LOAD LIMITS AT VARIOUS COLD INFLATION PRESSURES

	23	26	29	32	35	38	41	44	46	49	52	55	58
PSI	23	26	29	32	35	38	41	44	46	49	52	55	58
KPA	160	180	200	220	240	260	280	300	320	340	360	380	400
LBS	2,600	2,830	3,080	3,300	3,520	3,740	3,960	4,180	4,680	4,800	5,300	5,360	5,680
KG	1,180	1,285	1,400	1,500	1,600	1,700	1,800	1,900	2,120	2,180	2,360	2,430	2,575

141

340 / 80R18

	LOAD INDEX	TRA / APPLICATION	SPEC	ARTICLE #	APPROXIMATE INFLATED DIMENSIONS					
					RIM WIDTH [INCH / MM]	OD [INCH / MM]	OW [INCH / MM]	SLR [INCH / MM]	ROLLING CIRC [INCH / MM]	OTD [32ND / MM]
DURA FORCE UTILITY	143	R-4	-	004502	11.0 279	39.1 993	13.5 345	17.8 447	119.6 2,809	26 30.5
RADIAL DURA FORCE RT	143	R-4	-	375975	11.0 279	39.4 1,001	13.5 342	17.4 442	117.0 2,972	38 30.2

DURA FORCE UTILITY, RADIAL DURA FORCE RT **MAX SPEED 5 MPH | 10 KPH**

TIRE LOAD LIMITS AT VARIOUS COLD INFLATION PRESSURES

	23	26	29	32	35	38	41	44	46	49	52	55	58
PSI	23	26	29	32	35	38	41	44	46	49	52	55	58
KPA	160	180	200	220	240	260	280	300	320	340	360	380	400
LBS	2,830	3,080	3,300	3,640	3,860	4,180	4,400	4,680	4,940	5,200	5,360	5,680	6,000
KG	1,285	1,400	1,500	1,650	1,750	1,900	2,000	2,120	2,240	2,360	2,430	2,575	2,725

143



405 / 70R18

	LOAD INDEX	TRA / APPLICATION	SPEC	ARTICLE #	APPROXIMATE INFLATED DIMENSIONS					
					RIM WIDTH [INCH / MM]	OD [INCH / MM]	OW [INCH / MM]	SLR [INCH / MM]	ROLLING CIRC [INCH / MM]	OTD [32ND / MM]
DURAFORCE UTILITY	153	R-4	-	003997	13.0 330	40.7 1,034	16.4 417	18.3 465	128.0 3,251	32 25.4

DURAFORCE UTILITY

MAX SPEED 0 MPH | 0 KPH

TIRE LOAD LIMITS AT VARIOUS COLD INFLATION PRESSURES

PSI	22	25	29	33	36	40	44	47	51	54	58
KPA	150	175	200	225	250	275	300	325	350	375	400
LBS	5,611	6,371	7,099	7,793	8,455	9,105	9,833	10,538	11,321	12,103	12,875
KG	2,545	2,890	3,220	3,535	3,835	4,130	4,460	4,780	5,135	5,490	5,840

153

DURAFORCE UTILITY

*MAX SPEED 5 MPH | 10 KPH

TIRE LOAD LIMITS AT VARIOUS COLD INFLATION PRESSURES

PSI	22	25	29	33	36	40	44	47	51	54	58
KPA	150	175	200	225	250	275	300	325	350	375	400
LBS	3,505	3,979	4,431	4,872	5,291	5,699	6,140	6,592	7,077	7,562	8,047
KG	1,590	1,805	2,010	2,210	2,400	2,585	2,785	2,990	3,210	3,430	3,650

153

DURAFORCE UTILITY

MAX SPEED 5 MPH | 10 KPH

TIRE LOAD LIMITS AT VARIOUS COLD INFLATION PRESSURES

PSI	22	25	29	33	36	40	44	47	51	54	58
KPA	150	175	200	225	250	275	300	325	350	375	400
LBS	3,186	3,627	4,023	4,431	4,817	5,170	5,589	5,986	6,437	6,878	7,319
KG	1,445	1,645	1,825	2,010	2,185	2,345	2,535	2,715	2,920	3,120	3,320

153

DURAFORCE UTILITY

MAX SPEED 20 MPH | 30 KPH

TIRE LOAD LIMITS AT VARIOUS COLD INFLATION PRESSURES

PSI	22	25	29	33	36	40	44	47	51	54	58
KPA	150	175	200	225	250	275	300	325	350	375	400
LBS	2,624	2,976	3,318	3,649	3,957	4,255	4,597	4,927	5,291	5,666	6,019
KG	1,190	1,350	1,505	1,655	1,795	1,930	2,085	2,235	2,400	2,570	2,730

153

DURAFORCE UTILITY

MAX SPEED 25 MPH | 40 KPH

TIRE LOAD LIMITS AT VARIOUS COLD INFLATION PRESSURES

PSI	22	25	29	33	36	40	44	47	51	54	58
KPA	150	175	200	225	250	275	300	325	350	375	400
LBS	2,546	2,899	3,219	3,538	3,847	4,134	4,464	4,784	5,148	5,501	5,853
KG	1,155	1,315	1,460	1,605	1,745	1,875	2,025	2,170	2,335	2,495	2,655

153

DURAFORCE UTILITY

MAX SPEED 30 MPH | 50 KPH

TIRE LOAD LIMITS AT VARIOUS COLD INFLATION PRESSURES

PSI	22	25	29	33	36	40	44	47	51	54	58
KPA	150	175	200	225	250	275	300	325	350	375	400
LBS	2,480	2,811	3,131	3,439	3,737	4,023	4,332	4,652	4,993	5,335	5,677
KG	1,125	1,275	1,420	1,560	1,695	1,825	1,965	2,110	2,265	2,420	2,575

153

* One way distance of 600 meters

17.5LR24

	PLY/STAR RATING	TRA / APPLICATION	SPEC	ARTICLE #	APPROXIMATE INFLATED DIMENSIONS					
					RIM WIDTH [INCH / MM]	OD [INCH / MM]	OW [INCH / MM]	SLR [INCH / MM]	ROLLING CIRC [INCH / MM]	OTD [32ND / MM]
RADIAL ALL TRACTION UTILITY	2*	R-4	-	351989	15.0 381	48.7 1,237	17.7 450	21.3 541	146.0 3,708	32 25,5

RADIAL DURAFORCE RT

MAX SPEED 25 MPH | 40 KPH

TIRE LOAD LIMITS AT VARIOUS COLD INFLATION PRESSURES

PSI	20	23	26	29	32	35	38	41	44	46	49	52	55	58
KPA	140	160	180	200	220	240	260	280	300	320	340	360	380	400
LBS	4,080	4,540	-	-	-	-	-	-	-	-	-	-	-	-
KG	1,850	2,060	-	-	-	-	-	-	-	-	-	-	-	-

2*

"L" in tire size indicates "Low section height" tire.

500 / 70R24 19.5LR24*

	LOAD INDEX	TRA / APPLICATION	SPEC	ARTICLE #	APPROXIMATE INFLATED DIMENSIONS					
					RIM WIDTH [INCH / MM]	OD [INCH / MM]	OW [INCH / MM]	SLR [INCH / MM]	ROLLING CIRC [INCH / MM]	OTD [32ND / MM]
RADIAL DURAFORCE RT	157	R-4	-	371657	16.0 406	51.2 1,300	19.5 495	22.8 579	149.0 3,785	34 27.0
RADIAL DURAFORCE RT	164	R-4	-	376842	16.0 406	51.2 1,300	19.5 495	22.8 579	149.0 3,785	34 27.0

RADIAL DURAFORCE RT

MAX SPEED 25 MPH | 40 KPH

TIRE LOAD LIMITS AT VARIOUS COLD INFLATION PRESSURES

PSI	23	26	29	32	35	38	41	44	46	49	52	55	58
KPA	160	180	200	220	240	260	280	300	320	340	360	380	400
LBS	5,200	5,680	6,150	6,600	7,150	7,600	8,050	8,550	9,100	9,350	9,900	10,500	11,000
KG	2,360	2,575	2,800	3,000	3,250	3,450	3,650	3,875	4,125	4,250	4,500	4,750	5,000

157

164



COMPACT BIAS TIRES

215 / 70D15 27x8.50-15*

PLY RATING	TRA / APPLICATION	SPEC	ARTICLE #	APPROXIMATE INFLATED DIMENSIONS					MINIMUM DUAL SPACING [INCH]	RECOMMENDED RIM / FLANGE HEIGHT [INCH]	
				OD [INCH / MM]	OW [INCH / MM]	SLR [INCH / MM]	SLW [INCH / MM]	OTD [32ND / MM]			
DURAFORCE DT	8	NHS	-	360449	7.0 178	26.7 678	8.4 213	12.1 307	79.0 2,007	22 17.5	32.00/4.5

DURAFORCE DT

MAX SPEED 5 MPH | 10 KPH

TIRE LOAD LIMITS AT VARIOUS COLD INFLATION PRESSURES

	20	25	30	35	40	45	50	55	60
PSI	20	25	30	35	40	45	50	55	60
KPA	140	170	210	240	280	310	340	380	410
LBS	965	1,100	1,230	1,320	1,430	1,570	1,650	1,760	1,820
KG	437	500	560	600	650	710	750	800	825

8 PLY

260 / 65D15 27x10.50-15*

PLY RATING	TRA / APPLICATION	SPEC	ARTICLE #	APPROXIMATE INFLATED DIMENSIONS					MINIMUM DUAL SPACING [INCH]	RECOMMENDED RIM / FLANGE HEIGHT [INCH]	
				OD [INCH / MM]	OW [INCH / MM]	SLR [INCH / MM]	SLW [INCH / MM]	OTD [32ND / MM]			
DURAFORCE DT	8	NHS	-	360457	8.0 203	27.2 691	10.2 259	12.3 312	80.0 2,032	24 19.1	32.00/4.5

DURAFORCE DT

MAX SPEED 5 MPH | 10 KPH

TIRE LOAD LIMITS AT VARIOUS COLD INFLATION PRESSURES

	20	25	30	35	40	45	50	55	60
PSI	20	25	30	35	40	45	50	55	60
KPA	140	170	210	240	280	310	340	380	410
LBS	1,020	1,170	1,320	1,430	1,520	1,650	1,760	1,870	1,970
KG	462	530	600	650	690	750	800	850	895

8 PLY

390 / 60D15 31x15.50-15*

PLY/STAR RATING	TRA / APPLICATION	SPEC	ARTICLE #	APPROXIMATE INFLATED DIMENSIONS						
				RIM WIDTH [INCH / MM]	OD [INCH / MM]	OW [INCH / MM]	SLR [INCH / MM]	ROLLING CIRC [INCH / MM]	OTD [32ND / MM]	
DURAFORCE DT	8	NHS	-	360465	13.0 330	31.2 792	15.4 391	14.2 361	94.0 2,388	30 23,8

DURAFORCE DT

MAX SPEED 30 MPH | 50 KPH

TIRE LOAD LIMITS AT VARIOUS COLD INFLATION PRESSURES

	20	25	30	35	40	45
PSI	20	25	30	35	40	45
KPA	140	170	210	240	280	310
LBS	1,710	1,930	2,105	2,340	2,540	2,760
KG	775	875	975	1,060	1,150	1,250

8 PLY

MAXIMUM SPEED% CHANGE IN LOAD

20 MPH (30 KM/H)	+12%
10 MPH (15 KM/H)	+32%
5 MPH (10 KM/H)	+58%
CREEP*	+100%
STATIONARY	+165%

* "CREEP" speed is a travel rate of not over 200 ft (61m) in a 30 minute period.



11L - 16

	PLY/STAR RATING	TRA / APPLICATION	SPEC	ARTICLE #	APPROXIMATE INFLATED DIMENSIONS					
					RIM WIDTH [INCH / MM]	OD [INCH / MM]	OW [INCH / MM]	SLR [INCH / MM]	ROLLING CIRC [INCH / MM]	OTD [32ND / MM]
INDUSTRIAL SPECIAL	10	F-3	-	314625	8.0 203	31.8 808	11.0 279	14.5 368	96.0 2,438	14 11.1
INDUSTRIAL SPECIAL	12	F-3	-	326089	8.0 203	31.8 808	11.0 279	14.5 368	96.0 2,438	14 11.1

INDUSTRIAL SPECIAL

MAX SPEED 25 MPH | 40 KPH

TIRE LOAD LIMITS AT VARIOUS COLD INFLATION PRESSURES

PSI	24	28	32	36	40	44	48	52	56	60	64
KPA	170	190	220	250	280	300	330	360	390	410	440
LBS	1,480	1,650	1,760	1,930	2,090	2,200	2,340	2,470	2,540	2,680	2,760
KG	670	750	800	875	950	1,000	1,060	1,120	1,150	1,215	1,250

8 PLY

12 PLY

14.5 / 75 - 16.1

	PLY/STAR RATING	TRA / APPLICATION	SPEC	ARTICLE #	APPROXIMATE INFLATED DIMENSIONS					
					RIM WIDTH [INCH / MM]	OD [INCH / MM]	OW [INCH / MM]	SLR [INCH / MM]	ROLLING CIRC [INCH / MM]	OTD [32ND / MM]
INDUSTRIAL SPECIAL	10	F-3	-	321567	11.0 279	36.2 919	14.7 373	16.4 417	109.0 2,769	19 15.1

INDUSTRIAL SPECIAL

MAX SPEED 25 MPH | 40 KPH

TIRE LOAD LIMITS AT VARIOUS COLD INFLATION PRESSURES

PSI	24	28	32	36	40
KPA	170	190	220	250	280
LBS	2,270	2,540	2,760	3,000	3,200
KG	1,030	1,150	1,250	1,360	1,450

10 PLY

265 / 70D16.5 10-16.5*

	PLY/STAR RATING	TRA / APPLICATION	SPEC	ARTICLE #	APPROXIMATE INFLATED DIMENSIONS					
					RIM WIDTH [INCH / MM]	OD [INCH / MM]	OW [INCH / MM]	SLR [INCH / MM]	ROLLING CIRC [INCH / MM]	OTD [32ND / MM]
DURAFORCE DT	8	NHS	-	360473	8.25 210	30.4 772	10.0 254	13.6 345	90.0 2,286	26 20.6
DURAFORCE HD	8	NHS	-	362123	8.25 210	31.0 787	11.0 279	13.8 351	-	20.0 15.9
DURAFORCE SDT	10	NHS	-	365707	8.25 210	30.8 782	10.4 264	13.8 351	91.0 2,311	20.0 15.9

DURAFORCE DT, DURAFORCE HD, DURAFORCE SDT

MAX SPEED 5 MPH | 10 KPH

TIRE LOAD LIMITS AT VARIOUS COLD INFLATION PRESSURES

PSI	30	35	40	45	50	55	60	65	70	75
KPA	210	240	280	310	340	380	410	450	480	520
LBS	2,760	3,020	3,260	3,500	3,720	3,930	4,140	4,340	-	4,710
KG	1,250	1,370	1,480	1,590	1,685	1,785	1,880	1,970	-	2,135

8 PLY
10 PLY

305 / 70D16.5 12-16.5*

	PLY/STAR RATING	TRA / APPLICATION	SPEC	ARTICLE #	APPROXIMATE INFLATED DIMENSIONS					
					RIM WIDTH [INCH / MM]	OD [INCH / MM]	OW [INCH / MM]	SLR [INCH / MM]	ROLLING CIRC [INCH / MM]	OTD [32ND / MM]
DURAFORCE DT	10	NHS	-	360414	9.75 248	32.7 831	12.3 312	14.7 373	97.0 2,464	28 22.2
DURAFORCE DT	12	NHS	-	373170	9.75 248	32.7 831	12.3 312	14.8 376	98.0 2,489	28 22.2
DURAFORCE HD	10	NHS	-	362131	9.75 248	32.1 815	12.7 323	14.8 376	98.0 2,489	23 18.3
DURAFORCE SDT	12	NHS	-	365724	9.75 248	32.7 831	11.6 295	15.0 381	98.0 2,489	47 37.3

DURAFORCE DT, DURAFORCE HD, DURAFORCE SDT

MAX SPEED 5 MPH | 10 KPH

TIRE LOAD LIMITS AT VARIOUS COLD INFLATION PRESSURES

PSI	30	35	40	45	50	55	60	65	70	75	80
KPA	210	240	280	310	340	380	410	450	480	520	550
LBS	3,560	3,900	4,220	4,520	4,810	5,080	5,340	5,600	-	-	6,320
KG	1,615	1,770	1,915	2,050	2,180	2,305	2,420	2,540	-	-	2,865

10 PLY
12 PLY



330 / 55D16.5 31x13.00-16.5

	PLY/STAR RATING	TRA / APPLICATION	SPEC	ARTICLE #	APPROXIMATE INFLATED DIMENSIONS					
					RIM WIDTH [INCH / MM]	OD [INCH / MM]	OW [INCH / MM]	SLR [INCH / MM]	ROLLING CIRC [INCH / MM]	OTD [32ND / MM]
DURAFORCE DT	10	NHS	-	360481	9.75 248	31.0 787	13.0 330	13.7 348	90.0 2,286	26 20.6

DURAFORCE DT **MAX SPEED 5 MPH | 10 KPH**

TIRE LOAD LIMITS AT VARIOUS COLD INFLATION PRESSURES

	30	35	40	45	50	55	60
PSI	30	35	40	45	50	55	60
60	210	240	280	310	340	380	410
LBS	3,535	3,870	4,185	4,480	4,765	5,040	5,300
KG	1,605	1,755	1,900	2,030	2,160	2,285	2,405

10 PLY

14 - 17.5

	PLY/STAR RATING	TRA / APPLICATION	SPEC	ARTICLE #	APPROXIMATE INFLATED DIMENSIONS					
					RIM WIDTH [INCH / MM]	OD [INCH / MM]	OW [INCH / MM]	SLR [INCH / MM]	ROLLING CIRC [INCH / MM]	OTD [32ND / MM]
SUPER TRACTION DUPLEX	10	NHS	-	416177	10.5 267	36.8 935	13.8 351	16.2 411	107.0 2,718	22 17.5

SUPER TRACTION DUPLEX **MAX SPEED 5 MPH | 10 KPH**

TIRE LOAD LIMITS AT VARIOUS COLD INFLATION PRESSURES

	30	35	40	45	50	55
PSI	30	35	40	45	50	55
60	201	240	280	310	340	380
LBS	4,820	5,260	5,700	6,100	6,500	6,850
KG	2,185	2,385	2,585	2,765	2,950	3,105

10 PLY

355 / 70D17.5 14-17.5

	PLY/STAR RATING	TRA / APPLICATION	SPEC	ARTICLE #	APPROXIMATE INFLATED DIMENSIONS					
					RIM WIDTH [INCH / MM]	OD [INCH / MM]	OW [INCH / MM]	SLR [INCH / MM]	ROLLING CIRC [INCH / MM]	OTD [32ND / MM]
DURAFORCE HD	10	NHS	-	362158	10.5 267	36.8 935	13.8 351	16.2 411	107.0 2,718	24 19.1
DURAFORCE ND	14	NHS	-	361674	10.5 267	36.3 922	13.8 351	16 406	105 2,667	24 19.1
DURAFORCE SDT	14	NHS	-	365741	10.5 267	36.8 935	13.8 351	16.2 411	107 2,718	24 19.1

DURAFORCE HD, DURAFORCE ND, DURAFORCE SDT **MAX SPEED 5 MPH | 10 KPH**

TIRE LOAD LIMITS AT VARIOUS COLD INFLATION PRESSURES

	30	35	40	45	50	55	60	65	70	75	80
PSI	30	35	40	45	50	55	60	65	70	75	80
KPA	210	240	280	310	340	380	410	450	480	520	550
LBS	4,820	5,260	5,700	6,100	6,500	6,850	7,220	7,560	-	-	8,540
KG	2,185	2,385	2,585	2,765	2,950	3,105	3,275	3,430	-	-	3,875

10 PLY

14 PLY

10.5 / 80 - 18

	PLY/STAR RATING	TRA / APPLICATION	SPEC	ARTICLE #	APPROXIMATE INFLATED DIMENSIONS					
					RIM WIDTH [INCH / MM]	OD [INCH / MM]	OW [INCH / MM]	SLR [INCH / MM]	ROLLING CIRC [INCH / MM]	OTD [32ND / MM]
ALL TRACTION UTILITY	10	I-3	-	351741	9.0 229	34.4 874	10.8 274	16.0 406	104.0 2,642	28 22.2

ALL TRACTION UTILITY

TIRE LOAD LIMITS AT VARIOUS COLD INFLATION PRESSURES

MAX SPEED	0 MPH / 0 KPH	5 MPH / 10 KPH	25 MPH / 40 KPH	30 MPH / 50 KPH
PSI	54	54	54	54
KPA	375	375	375	375
LBS	10,630	6,930	4,620	4,200
KG	4,820	3,145	2,095	1,905

10 PLY

12.5 / 80 - 18

	PLY/STAR RATING	TRA / APPLICATION	SPEC	ARTICLE #	APPROXIMATE INFLATED DIMENSIONS					
					RIM WIDTH [INCH / MM]	OD [INCH / MM]	OW [INCH / MM]	SLR [INCH / MM]	ROLLING CIRC [INCH / MM]	OTD [32ND / MM]
SUPER TRACTION LOADER	12	I-3	-	359912	9.0 229	37.8 960	12.1 307	16.1 409	110.0 2,794	32 25.4

SUPER TRACTION LOADER

TIRE LOAD LIMITS AT VARIOUS COLD INFLATION PRESSURES

MAX SPEED	0 MPH / 0 KPH	5 MPH / 10 KPH	25 MPH / 40 KPH	30 MPH / 50 KPH
PSI	54	54	54	54
KPA	375	375	375	375
LBS	11,970	7,800	5,200	7,740
KG	5,430	3,540	2,360	2,150

12 PLY

15 / 19.5

	PLY/STAR RATING	TRA / APPLICATION	SPEC	ARTICLE #	APPROXIMATE INFLATED DIMENSIONS					
					RIM WIDTH [INCH / MM]	OD [INCH / MM]	OW [INCH / MM]	SLR [INCH / MM]	ROLLING CIRC [INCH / MM]	OTD [32ND / MM]
SUPER TRACTION DUPLEX	12	NHS	-	416517	11.75 298	40.8 1,036	15.7 399	19.0 483	122.0 3,099	26 20.6

SUPER TRACTION DUPLEX

MAX SPEED 5 MPH | 10 KPH

TIRE LOAD LIMITS AT VARIOUS COLD INFLATION PRESSURES

	30	35	40	45	50	55	60
PSI	30	35	40	45	50	55	60
KPA	210	240	280	310	340	380	410
LBS	6,130	6,710	7,250	7,770	8,260	8,740	9,190
KG	2,780	3,045	3,290	3,525	3,745	3,965	4,170

12 PLY



385 / 65D19.5 15-19.5

PLY/STAR RATING	TRA / APPLICATION	SPEC	ARTICLE #	APPROXIMATE INFLATED DIMENSIONS						
				RIM WIDTH [INCH / MM]	OD [INCH / MM]	OW [INCH / MM]	SLR [INCH / MM]	ROLLING CIRC [INCH / MM]	OTD [32ND / MM]	
DURFORCE ND	16	NHS	-	361690	11.75 298	40.1 1,019	15.3 389	18.0 457	119.0 3,023	25 19.8

DURAFORCE ND MAX SPEED 0 MPH | 0 KPH

TIRE LOAD LIMITS AT VARIOUS COLD INFLATION PRESSURES

	70	75	80	85	90	95	100
PSI	70	75	80	85	90	95	100
KPA	480	520	550	585	620	655	690
LBS	-	-	-	-	13,600	14,300	14,800
KG	-	-	-	-	6,169	6,486	6,713

16 PLY

DURAFORCE ND MAX SPEED 5 MPH | 10 KPH

TIRE LOAD LIMITS AT VARIOUS COLD INFLATION PRESSURES

	70	75	80	85	90	95	100
PSI	70	75	80	85	90	95	100
KPA	480	520	550	585	620	655	690
LBS	-	-	-	-	10,500	11,000	11,400
KG	-	-	-	-	4,763	4,990	5,171

16 PLY

DURAFORCE ND MAX SPEED 10 MPH | 15 KPH

TIRE LOAD LIMITS AT VARIOUS COLD INFLATION PRESSURES

	70	75	80	85	90	95	100
PSI	70	75	80	85	90	95	100
KPA	480	520	550	585	620	655	690
LBS	-	-	-	-	9,100	9,350	9,650
KG	-	-	-	-	4,128	4,241	4,377

16 PLY

DURAFORCE ND MAX SPEED 20 MPH | 30 KPH

TIRE LOAD LIMITS AT VARIOUS COLD INFLATION PRESSURES

	70	75	80	85	90	95	100
PSI	70	75	80	85	90	95	100
KPA	480	520	550	585	620	655	690
LBS	-	-	-	-	8,550	8,800	9,100
KG	-	-	-	-	3,878	3,992	4,128

16 PLY

DURAFORCE ND MAX SPEED 25 MPH | 40 KPH

TIRE LOAD LIMITS AT VARIOUS COLD INFLATION PRESSURES

	70	75	80	85	90	95	100
PSI	70	75	80	85	90	95	100
KPA	480	520	550	585	620	655	690
LBS	-	-	-	-	8,250	8,550	8,800
KG	-	-	-	-	3,742	3,878	3,992

16 PLY

DURAFORCE ND MAX SPEED 30 MPH | 50 KPH

TIRE LOAD LIMITS AT VARIOUS COLD INFLATION PRESSURES

	70	75	80	85	90	95	100
PSI	70	75	80	85	90	95	100
KPA	480	520	550	585	620	655	690
LBS	-	-	-	-	8,050	8,250	8,550
KG	-	-	-	-	3,651	3,741	3,878

16 PLY



445 / 65D19.5 18-19.5*

	PLY/STAR RATING	TRA / APPLICATION	SPEC	ARTICLE #	APPROXIMATE INFLATED DIMENSIONS					
					RIM WIDTH [INCH / MM]	OD [INCH / MM]	OW [INCH / MM]	SLR [INCH / MM]	ROLLING CIRC [INCH / MM]	OTD [32ND / MM]
DURFORCE ND	16	NHS	-	361712	14.0 356	43.2 1,097	18.0 457	19.4 493	128.0 3,251	28 22.2

DURAFORCE ND **MAX SPEED 0 MPH | 0 KPH**

TIRE LOAD LIMITS AT VARIOUS COLD INFLATION PRESSURES

	70 KPA	75 520	80 550	85 585
LBS	15,200	15,700	16,500	17,100
KG	6,895	7,121	7,484	7,756

16 PLY

DURAFORCE ND **MAX SPEED 5 MPH | 10 KPH**

TIRE LOAD LIMITS AT VARIOUS COLD INFLATION PRESSURES

	70 KPA	75 520	80 550	85 585
LBS	11,400	12,000	12,800	13,200
KG	5,171	5,443	5,806	5,987

16 PLY

DURAFORCE ND **MAX SPEED 10 MPH | 15 KPH**

TIRE LOAD LIMITS AT VARIOUS COLD INFLATION PRESSURES

	70 KPA	75 520	80 550	85 585
LBS	9,900	10,500	11,000	11,400
KG	4,491	4,763	4,990	5,171

16 PLY

DURAFORCE ND **MAX SPEED 20 MPH | 30 KPH**

TIRE LOAD LIMITS AT VARIOUS COLD INFLATION PRESSURES

	70 KPA	75 520	80 550	85 585
LBS	9,350	9,650	10,200	10,500
KG	4,241	4,377	4,627	4,763

16 PLY

DURAFORCE ND **MAX SPEED 25 MPH | 40 KPH**

TIRE LOAD LIMITS AT VARIOUS COLD INFLATION PRESSURES

	70 KPA	75 520	80 550	85 585
LBS	8,800	9,350	9,900	10,200
KG	3,992	4,241	4,491	4,627

16 PLY

DURAFORCE ND **MAX SPEED 30 MPH | 50 KPH**

TIRE LOAD LIMITS AT VARIOUS COLD INFLATION PRESSURES

	70 KPA	75 520	80 550	85 585
LBS	8,800	9,100	9,650	9,900
KG	3,992	4,128	4,377	4,491

16 PLY



15 - 22.5

	PLY/STAR RATING	TRA / APPLICATION	SPEC	ARTICLE #	APPROXIMATE INFLATED DIMENSIONS					
					RIM WIDTH [INCH / MM]	OD [INCH / MM]	OW [INCH / MM]	SLR [INCH / MM]	ROLLING CIRC [INCH / MM]	OTD [32ND / MM]
SUPER TRACTION DUPLEX	16	NHS	-	359599	11.75 298	42.7 1,085	15.6 396	19.4 493	128.0 3,251	25 19.8

SUPER TRACTION DUPLEX **MAX SPEED 0 MPH | 0 KPH**

TIRE LOAD LIMITS AT VARIOUS COLD INFLATION PRESSURES

	70	75	80	85	90	95	100
PSI	70	75	80	85	90	95	100
KPA	480	520	550	585	620	655	690
LBS	12,800	13,200	13,900	14,300	14,800	15,700	16,100
KG	5,806	5,987	6,305	6,486	6,713	7,121	7,303

16 PLY

SUPER TRACTION DUPLEX **MAX SPEED 5 MPH | 10 KPH**

TIRE LOAD LIMITS AT VARIOUS COLD INFLATION PRESSURES

	70	75	80	85	90	95	100
PSI	70	75	80	85	90	95	100
KPA	480	520	550	585	620	655	690
LBS	9,650	10,200	10,700	11,000	11,400	12,000	12,300
KG	4,377	4,627	4,853	4,990	5,171	5,443	5,579

16 PLY

SUPER TRACTION DUPLEX **MAX SPEED 10 MPH | 15 KPH**

TIRE LOAD LIMITS AT VARIOUS COLD INFLATION PRESSURES

	70	75	80	85	90	95	100
PSI	70	75	80	85	90	95	100
KPA	480	520	550	585	620	655	690
LBS	8,550	8,800	9,100	9,650	9,900	10,200	10,700
KG	3,878	3,992	4,128	4,377	4,491	4,627	4,853

16 PLY

SUPER TRACTION DUPLEX **MAX SPEED 20 MPH | 30 KPH**

TIRE LOAD LIMITS AT VARIOUS COLD INFLATION PRESSURES

	70	75	80	85	90	95	100
PSI	70	75	80	85	90	95	100
KPA	480	520	550	585	620	655	690
LBS	7,850	8,250	8,550	9,100	9,350	9,650	9,900
KG	3,561	3,742	3,878	4,128	4,241	4,377	4,491

16 PLY

SUPER TRACTION DUPLEX **MAX SPEED 25 MPH | 40 KPH**

TIRE LOAD LIMITS AT VARIOUS COLD INFLATION PRESSURES

	70	75	80	85	90	95	100
PSI	70	75	80	85	90	95	100
KPA	480	520	550	585	620	655	690
LBS	7,600	7,850	8,250	8,550	9,100	9,350	9,650
KG	3,447	3,561	3,742	3,878	4,128	4,241	4,377

16 PLY

SUPER TRACTION DUPLEX **MAX SPEED 30 MPH | 50 KPH**

TIRE LOAD LIMITS AT VARIOUS COLD INFLATION PRESSURES

	70	75	80	85	90	95	100
PSI	70	75	80	85	90	95	100
KPA	480	520	550	585	620	655	690
LBS	7,400	7,600	8,050	8,250	8,800	9,100	9,350
KG	3,357	3,447	3,651	3,742	3,992	4,128	4,241

16 PLY



16.9 - 24

	PLY/STAR RATING	TRA / APPLICATION	SPEC	ARTICLE #	APPROXIMATE INFLATED DIMENSIONS					
					RIM WIDTH [INCH / MM]	OD [INCH / MM]	OW [INCH / MM]	SLR [INCH / MM]	ROLLING CIRC [INCH / MM]	OTD [32ND / MM]
ALL TRACTION UTILITY	12	R-4	-	363990	15.0 381	51.9 1,318	16.9 429	23.0 584	152.0 3,861	34 27.0

ALL TRACTION UTILITY

MAX SPEED 25 MPH | 40 KPH

TIRE LOAD LIMITS AT VARIOUS COLD INFLATION PRESSURES

	20 KPA	22 150	24 170	26 180	28 190	30 210	32 220	34 230	36 250	38 260
LBS	4,680	4,940	5,200	5,520	5,840	6,150	6,400	-	-	7,150
KG	2,120	2,240	2,360	2,500	2,650	2,800	2,900	-	-	3,250

12 PLY

17.5L - 24

	PLY/STAR RATING	TRA / APPLICATION	SPEC	ARTICLE #	APPROXIMATE INFLATED DIMENSIONS					
					RIM WIDTH [INCH / MM]	OD [INCH / MM]	OW [INCH / MM]	SLR [INCH / MM]	ROLLING CIRC [INCH / MM]	OTD [32ND / MM]
ALL TRACTION UTILITY	10	R-4	-	325880	15.0 381	48.9 1,242	17.5 445	22.2 564	145.0 3,683	32 25.4

ALL TRACTION UTILITY

MAX SPEED 25 MPH | 40 KPH

TIRE LOAD LIMITS AT VARIOUS COLD INFLATION PRESSURES

	20 KPA	22 150	24 170	26 180	28 190	30 210	32 220
LBS	4,400	4,680	5,080	5,360	5,520	5,840	6,150
KG	2,000	2,120	2,300	2,430	2,500	2,650	2,800

10 PLY

18.4 - 24

	PLY/STAR RATING	TRA / APPLICATION	SPEC	ARTICLE #	APPROXIMATE INFLATED DIMENSIONS					
					RIM WIDTH [INCH / MM]	OD [INCH / MM]	OW [INCH / MM]	SLR [INCH / MM]	ROLLING CIRC [INCH / MM]	OTD [32ND / MM]
ALL TRACTION UTILITY	8	R-4	-	316083	16.0 406	54.1 1,374	18.4 467	24.0 610	161.0 4,089	35 27.8
ALL TRACTION UTILITY	12	R-4	-	355224	16.0 406	54.1 1,374	18.4 467	24.0 610	161.0 4,089	35 27.8

ALL TRACTION UTILITY

MAX SPEED 25 MPH | 40 KPH

TIRE LOAD LIMITS AT VARIOUS COLD INFLATION PRESSURES

	20 KPA	22 150	24 170	26 180	28 190	30 210	32 220	34 230	36 250
LBS	5,520	5,840	6,400	6,600	6,950	7,400	7,600	-	8,250
KG	2,500	2,650	2,900	3,000	3,150	3,350	3,450	-	3,750

8 PLY

12 PLY



19.5L - 24

	PLY/STAR RATING	TRA / APPLICATION	SPEC	ARTICLE #	APPROXIMATE INFLATED DIMENSIONS					
					RIM WIDTH [INCH / MM]	OD [INCH / MM]	OW [INCH / MM]	SLR [INCH / MM]	ROLLING CIRC [INCH / MM]	OTD [32ND / MM]
ALL TRACTION UTILITY	10	R-4	-	359343	16.0 406	51.5 1,308	19.5 495	23.0 584	151.0 3,835	34 27.0
ALL TRACTION UTILITY	12	R-4	-	380259	16.0 406	51.5 1,308	19.5 495	23.0 584	151.0 3,835	34 27.0

ALL TRACTION UTILITY **MAX SPEED 25 MPH | 40 KPH**

TIRE LOAD LIMITS AT VARIOUS COLD INFLATION PRESSURES

	20 KPA	22 150	24 170	26 180	28 190	30 210	32 220	34 230
LBS	5,200	5,680	6,000	6,400	6,600	6,950	7,400	7,600
KG	2,360	2,575	2,725	2,900	3,000	3,150	3,350	3,450

10 PLY 12 PLY

21L - 24

	PLY/STAR RATING	TRA / APPLICATION	SPEC	ARTICLE #	APPROXIMATE INFLATED DIMENSIONS					
					RIM WIDTH [INCH / MM]	OD [INCH / MM]	OW [INCH / MM]	SLR [INCH / MM]	ROLLING CIRC [INCH / MM]	OTD [32ND / MM]
ALL TRACTION UTILITY	12	R-4	-	321370	18.0 457	54.2 1,377	21.0 533	23.4 594	156.0 3,962	35 27.8
ALL TRACTION UTILITY	16	R-4	-	327727	18.0 457	54.2 1,377	21.0 533	23.4 594	156.0 3,962	35 27.8
ALL TRACTION UTILITY	18	R-4	-	372762	18.0 457	54.2 1,377	21.0 533	23.4 594	156.0 3,962	35 27.8

ALL TRACTION UTILITY **MAX SPEED 25 MPH | 40 KPH**

TIRE LOAD LIMITS AT VARIOUS COLD INFLATION PRESSURES

	20 KPA	22 150	24 170	26 180	28 190	30 210	32 220	34 230	36 250	38 260	40 280	44 300
LBS	6,150	6,600	6,950	7,400	7,850	8,050	8,550	-	-	-	9,900	10,500
KG	2,800	3,000	3,150	3,350	3,550	3,650	3,875	-	-	-	4,500	4,750

12 PLY 16 PLY

18 PLY

14.9 - 28

	PLY/STAR RATING	TRA / APPLICATION	SPEC	ARTICLE #	APPROXIMATE INFLATED DIMENSIONS					
					RIM WIDTH [INCH / MM]	OD [INCH / MM]	OW [INCH / MM]	SLR [INCH / MM]	ROLLING CIRC [INCH / MM]	OTD [32ND / MM]
ALL TRACTION UTILITY	8	R-4	-	306371	13.0 330	52.9 1,344	14.9 378	24.2 615	157.0 3,988	32 25.4

ALL TRACTION UTILITY **MAX SPEED 25 MPH | 40 KPH**

TIRE LOAD LIMITS AT VARIOUS COLD INFLATION PRESSURES

	20 KPA	22 150	24 170	26 180	28 190	30 210
LBS	4,080	4,300	4,680	4,940	5,080	5,360
KG	1,850	1,950	2,120	2,240	2,300	2,430

8 PLY



16.9 - 28

	PLY/STAR RATING	TRA / APPLICATION	SPEC	ARTICLE #	APPROXIMATE INFLATED DIMENSIONS					
					RIM WIDTH [INCH / MM]	OD [INCH / MM]	OW [INCH / MM]	SLR [INCH / MM]	ROLLING CIRC [INCH / MM]	OTD [32ND / MM]
ALL TRACTION UTILITY	8	R-4	-	000900	15.0 381	55.9 1,420	16.9 429	25.0 635	164.0 4,166	34 27.0
ALL TRACTION UTILITY	12	R-4	-	379307	15.0 381	55.9 1,420	16.9 429	25.0 635	164.0 4,166	34 27.0

ALL TRACTION UTILITY **MAX SPEED 25 MPH | 40 KPH**

TIRE LOAD LIMITS AT VARIOUS COLD INFLATION PRESSURES

	20	22	24	26	28	30	32	34	36	38
PSI	140	150	170	180	190	210	220	230	250	260
KPA	4,940	5,200	5,680	6,000	6,150	6,600	6,800	-	-	7,600
LBS	2,240	2,360	2,575	2,725	2,800	3,000	3,075	-	-	3,450
KG										

8 PLY 12 PLY

18.4 - 28

	PLY/STAR RATING	TRA / APPLICATION	SPEC	ARTICLE #	APPROXIMATE INFLATED DIMENSIONS					
					RIM WIDTH [INCH / MM]	OD [INCH / MM]	OW [INCH / MM]	SLR [INCH / MM]	ROLLING CIRC [INCH / MM]	OTD [32ND / MM]
ALL TRACTION UTILITY	12	R-4	-	355410	16.0 406	58.1 1,476	18.4 467	26.0 660	171.0 4,343	35 27.8

ALL TRACTION UTILITY **MAX SPEED 25 MPH | 40 KPH**

TIRE LOAD LIMITS AT VARIOUS COLD INFLATION PRESSURES

	20	22	24	26	28	30	32	34	36
PSI	140	150	170	180	190	210	220	230	250
KPA	5,840	6,400	6,800	7,150	7,400	7,850	8,250	-	8,800
LBS	2,650	2,900	3,075	3,250	3,350	3,550	3,750	-	4,000
KG									

12 PLY

21L - 28

	PLY/STAR RATING	TRA / APPLICATION	SPEC	ARTICLE #	APPROXIMATE INFLATED DIMENSIONS					
					RIM WIDTH [INCH / MM]	OD [INCH / MM]	OW [INCH / MM]	SLR [INCH / MM]	ROLLING CIRC [INCH / MM]	OTD [32ND / MM]
ALL TRACTION UTILITY	14	R-4	-	356093	18.0 457	58.2 1,478	20.9 531	26.3 668	172.0 4,369	36 28.6

ALL TRACTION UTILITY **MAX SPEED 25 MPH | 40 KPH**

TIRE LOAD LIMITS AT VARIOUS COLD INFLATION PRESSURES

	20	22	24	26	28	30	32	34	36
PSI	140	150	170	180	190	210	220	230	250
KPA	6,600	6,950	7,400	7,850	8,250	8,800	9,100	-	9,900
LBS	3,000	3,150	3,350	3,550	3,750	4,000	4,125	-	4,500
KG									

14 PLY

REMARKS & SPECIAL OPERATIONS

BOTH RULES OF 1.1 AND 1.2 CAN'T BE APPLIED AT THE SAME TIME.

1.1 Excess Load

Due to the specialized nature of Off-The-Road vehicle usage, loads in excess of those in the appropriate above-listed load tables are often encountered.

These excess loads result from items such as actual vehicle weight exceeding the design weight, varying density of materials, field modifications to the equipment, load transfer, etc.

Only under these conditions, the actual tire load in service may exceed the above load ratings for the tire(*) by an amount not greater than shown in the following table:

For Radial Tires

	E2, E3, E4*	L**	(except for underground vehicles)
Maximum Excess Load	7%	7%	
Maximum Excess Pressure	14%	14%	
Maximum Pressure	800kPa	825kPa	
	<i>116psi</i>	<i>120psi</i>	

When excess loads are encountered, cold inflation pressures must be increased to compensate for higher loads. For each 1% increase in load, the inflation pressure must be increased by 2%.

THE MAXIMUM EXCESS LOADS WILL RESULT IN REDUCED TIRE PERFORMANCE.

For Bias Tires

	E2, E3, E4*	L**		(except for underground vehicles)
			L5/L5S***	
Maximum Excess Load	15%	15%	0%	
Maximum Excess Pressure	30%	30%	+100kPa	
Maximum Pressure	825kPa	825kPa		
	<i>120psi</i>	<i>120psi</i>		

When excess loads are encountered, cold inflation pressures must be increased to compensate for higher loads. For each 1% increase in load, the inflation pressure must be increased by 2%.

*except following sizes on the list

9.00-20	10.00-20	11.00-20
---------	----------	----------

**except following sizes on the list

27x8.50-15	10-16.5	15.5/70-18	16.9-24
33x12.5-15	12-16.5	42x17-20	18.4-24
12.5/70-16	15.5/60-18	17.5/65-20	

***For L5/L5S tires following sizes on the list, on front tires for front end loaders, it is permissible to increase inflation pressure up to 100kPa (15psi) above, with no increase in load. (Maximum inflation pressure should not exceed 825 kPa (120psi))

17.5-25	26.5-25	35/65-33	50/65-51
20.5-25	29.5-25	40/65-39	65/65-57
23.5-25	29.5-29	45/65-45	

THE MAXIMUM EXCESS LOADS WILL RESULT IN REDUCED TIRE PERFORMANCE.

1.2 The Variation in Load Carrying Capacity with Operating Speed

For Radial Tires

Maximum Speed (km/h)	G	L*
Static		+60%
Creep		+30%
5		+14%
10		0
15	-	-13%
20		-
25		-20%
30		
35		-26%
40	0	-30%
45	-	
50	-9%	
55	-	
60	-18%	
65	-27%	
70		
75		
80		
80<		

(except for underground vehicles)

Reference speed for calculating load variance

* About the size of 55.5/80R57 and 60/80R57, consult a Firestone representative.

THIS TABLE DOESN'T SECURE TO PREVENT THE RISK DERIVED FROM HEAT BUILDUP.

For Bias Tires

Maximum Speed (km/h)	G	L*
Static		+60%
Creep		+30%
5		+14%
10		0
15	-	-13%
20		-
25		-20%
30		
35		-26%
40	0	-30%
45	-	
50	-9%	
55	-	
60	-18%	
65	-27%	
70		
75		
80		
80<		

(except for underground vehicles)

Reference speed for calculating load variance

*except following sizes on the list

27x8.50-15	10-16.5	15.5/70-18	16.9-24
33x12.5-15	12-16.5	42x17-20	18.4-24
12.5/70-16	15.5/60-18	17.5/65-20	

THIS TABLE DOESN'T SECURE TO PREVENT THE RISK DERIVED FROM HEAT BUILDUP.

2. Special Operations

Please check your operation to make sure of the Tire Load Limit.

Type/Service	Type of Operations	Reference No.
Earthmover	Standard	-
	When the vehicle is driven over the highway for delivery, or moved by an operator to a new job site - Drive-Away	2.2.1
Loader & Dozer	Distance of picking up and relocating material Less than 76m (one way) - Standard	-
	Distance of picking up and relocating material More than 76m (one way) - Load-and-Carry Operations	2.1.1
	Underground Load Haul Dump Service	2.1.2

2.1 For Load-and-Carry Operations

Service conditions of a loader is defined as "picking up material and relocating a short distance away, a maximum of 76m (250 feet), one way, with a maximum speed of 10km/h (5 mph)". However, a loader can pick up a load and transport such load to another location and return unloaded for a longer distance. This type of service is called as Load-and-Carry operations. Transportation usually occurs at low speeds, up to 25km/h (15 mph), and distances are limited.

The tires when used in Load-and-Carry operations may encounter heat problems especially on the front axle tires.

To avoid such problems, Firestone recommends the following operating conditions.

For tires over 33" inch rim diameter tires, careful study is required to maximize tire life while considering Ton- Kilometer-Per-Hour limits. Please consult a Firestone representative for more information.

If you need to use the tire beyond this recommendation, please consult a Firestone representative.

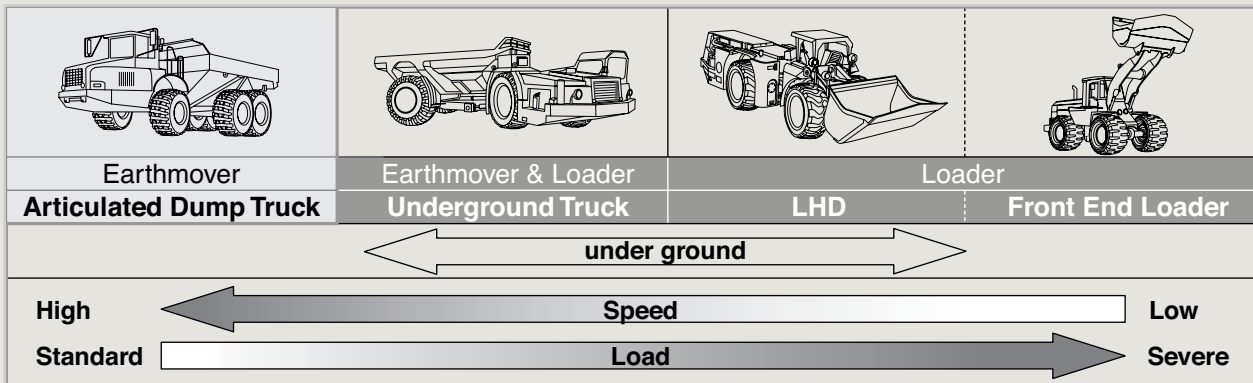

2.1.1 For Front End Loader Service

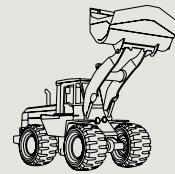

For Radial Tires

Tread Class	Inflation Pressure						Load Capacity* 10km/h (5mph)	Maximum Cycle Distance (m)	Allowable Average Work-shift Speed (km/h)
	Rim Diameter								
	29" and below			33" and above					
	Conventional size (95 series)		Wide base size (80, 65 series)		Wide base size (65 series)				
	★1	★2	★1	★2	★1	★2			
L2, L3							100% of STD. load	1800	16
L4									14
L5	550kpa (80psi)	825kpa (120psi)	500kpa (73psi)	650kpa (94psi)	600kpa (87psi)	750kpa (109psi)		1500	10
								1200	6
L5S								1200	5

*STD.load: Maximum permissible load at standard inflation pressure for respective tire size and star rating. Please refer to the load - inflation pressure table for loader and dozer service "10km/h (5mph) service" .

For Bias Tires

Tread Class	Inflation Pressure for Front Tires	Load Capacity* 10km/h (5mph)		Maximum Cycle Distance (m)	Allowable Average Work-shift Speed (km/h)
		Rim Diameter			
		29" and below	33" and above		
L2, L3	Standard inflation pressure + 100kpa (15psi)	90% of STD. load	**	1200	10
L4				500	
L5			85% of STD. load	300	3
L5S					

* STD.load: Maximum permissible load at standard inflation pressure for respective tire size and star rating. Please refer to the load - inflation pressure table for loader and dozer service "10km/h (5mph) service" .

** Not permissible

The inflation pressure should not exceed 825kPa (120psi).

2.1.2 For Load Haul Dump Service

Since a load haul dump (LHD) unit has a similar structure and operational characteristics as load and carry service on a front end loader, the following operating parameters are recommended.

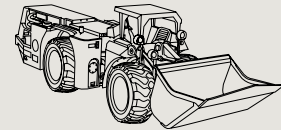

For Radial Tires

Tread Class	Inflation Pressure		Load Capacity* 10km/h (5mph)	Maximum Cycle Distance (m)	Allowable Average Work-shift Speed (km/h)
	Conventional size (95 series)	Wide base size (80, 65 series)			
	★2 D2A				
L2, L3					**
L4				1800	14
L5	825kpa (120psi)	650kpa (94psi)	100% of STD. load	1500	10
				1200	6
L5S				1200	5

*See note in Table 2.1.1. **Not permissible

For Bias Tires

Tread Class	Inflation Pressure for Front Tires	Load Capacity* 10km/h (5mph)		Maximum Cycle Distance (m)	Allowable Average Work-shift Speed (km/h)
		Rim Diameter			
		29" and below	33" and above		
L2, L3			**		
L4	Standard inflation pressure + 100kpa (15psi)	90% of STD. load	**	500	3
L5			85% of STD. load	300	
L5S					

*See note in Table 2.1.1. **Not permissible

The inflation pressure must meet 1.1 for maximum excess load.

2.2 Drive-Away Tires on Vehicles

2.2.1 Off-the-Road Tires for Earthmover

(1) Recommendations for Off-the-Road Tires

Because of the special extra-heavy construction of Off-the-Road tires, special precautions must be observed to protect these expensive tires when the vehicle is driven over the highway for delivery, or moved by an operator to a new job site. If the precautions are not observed, excessive tire heat is built up and the tires most likely will fail prematurely. These precautions are as follows and apply to tires on all vehicles in transit—driven or towed. Consult a Firestone Representative for specific information before starting out on a drive-away trip.

(2) Load and Pressure

[1] Vehicles must be empty during transportation.

[2] Inflation pressure is to be checked before starting, each break and adjusted to the pressure recommended for over-the-highway transit by Firestone.

[3] Inflation pressures are not to be reduced by “bleeding” tires during transportation.

[4] Periodical inflation pressure checks during transportation (i.e. every 2 hours) is recommended. Although operational pressure build-up in tires is normal during transportation, when it increases 20% or more than the cold pressure reading, it indicates over heating, and the vehicle should be stopped and a Firestone Representative should be consulted.

(3) Speed

[1] Regular tread tires (E-3):

(Note: For deep tread tires (E-4), always consult a Firestone Representative.)

a. Maximum highway speed:

Maximum Speed (Drive-Away)

		Maximum Speed	
Radial / Bias	Regular	50 km/h	30 mph
	Wide Base	32 km/h	20 mph

b. Stop for a 30-minute cooling period after each 80 km (50 miles) of driving or before 2 hours of continual operation, whichever comes first. (shown in the following figure)

c. One-hour minimum midday lunch stop should be observed during full day operations. (shown in the following figure)

Drive-Away

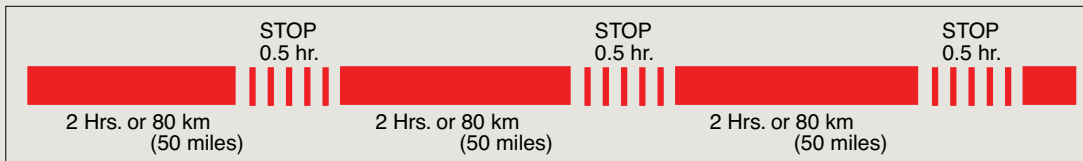

[2] Vehicles in transit should be accompanied by responsible personnel in a pilot car to enforce these precautions and maintain a check on equipment. This is good insurance for a valuable investment.

OTHER SPECIFICATION

1. O-Ring Specifications

Code No.	Applicable Size		Diameter		Inner Circumference	
	Radial	Bias	mm	inch	mm	inch
P-24A	13.00R24 TG	13.00-24 TG	6.6	0.26	1768	69.61
	14.00R24 TG	14.00-24 TG				
	16.00R24 TG	-				
P-25AX	14.00R25*	-	6.8	0.27	1779	70.04
	15.5R25	15.5-25				
	17.5R25	17.5-25				
	20.5R25	20.5-25				
	29.5R25	-				
	385/95R25	-				
	445/80R25	-				
	445/95R25	-				
	-	-				
P-25B	14.00R25**	-	9.8	0.39	1779	70.04
	16.00R25	16.00-25				
	17.5R25	17.5-25				
	18.00R25	18.00-25				
	20.5R25	20.5-25				
	21.00R25	21.00-25				
	23.5R25	23.5-25				
	26.5R25	26.5-25				
	29.5R25	29.5-25				
	30/65R25(750/65R25)	-				
	385/95R25	-				
	445/80R25	-				
	445/95R25	-				
	505/95R25	-				
	525/80R25	-				
	550/65R25	-				
	600/65R25	-				
	650/65R25	-				
	750/65R25	-				
P-29B	29.5R29	29.5-29	9.8	0.39	2127	83.74
	33.25R29	-				
	775/65R29	-				
	875/65R29	-				
	-	-				

Code No.	Applicable Size		Diameter		Inner Circumference	
	Radial	Bias	mm	inch	mm	inch
P-33B	18.00R33	18.00-33	9.8	0.39	2382	93.78
	21.00R33	-				
	35/65R33	35/65-33				
P-35B	21.00R35	21.00-35	9.8	0.39	2572	101.26
	24.00R35	-				
	29.5R35	-				
	33.25R35	-				
	37.25R35	37.25-35				
P-39B	37.5R39	-	9.8	0.39	2900	114.17
	-	40/65-39				
	40.5/75R39	-				
P-45B	45/65R45	45/65-45	9.8	0.39	3326	130.94
P-49B	27.00R49	-	9.8	0.39	3611	142.17
P-51C	30.00R51	-	12.7	0.5	3694	145.43
	33.00R51	-				
	36.00R51	-				
	50/65R51	50/65-51				
P-57C	37.00R57	-	12.7	0.5	4129	162.56
	40.00R57	-				
	42/90R57	-				
	46/90R57	-				
	50/90R57	-				
	55.5/80R57	-				
	60/80R57	-				
	-	65/65-57				
	-	-				
P-63C	53/80R63	-	12.7	0.5	4580	180.31
	59/80R63	-				

2. Flap Specifications

Flap	πD_B		G ₁		P	
	mm	inch	mm	inch	mm	inch
550/600-15	1175	46.3	4.0	0.16	129	5.1
650/700/750-15	1177	46.3	4.5	0.18	169	6.7
12/65B-15	1196	47.1	7.0	0.28	270	10.6
750/825AR15	1201	47.3	6.0	0.24	184	7.2
750/825-R16	1255	49.4	5.0	0.20	174	6.9
200D1000-R15	1201	47.3	6.5	0.26	205	8.1
700A825-R20	1255	49.4	5.0	0.20	180	7.1
900A111-R20	1201	47.3	6.0	0.24	205	8.1
1100B13/80-R20	1594	62.8	6.5	0.26	218	8.6
1400/14/80R20	1594	62.8	8.5	0.33	240	9.4
1300A1600-20	1618	63.7	8.0	0.31	246	9.7
42x17-20	1576	62.1	9.0	0.35	390	15.4
14/70-20	1587	62.5	9.0	0.35	331	13.0
1300-24	1916	75.4	9.0	0.35	229	9.0
1200A1400-24,25	1942	76.5	9.0	0.35	232	9.1
1100B1300-R24	1922	75.7	7.5	0.30	220	8.7
1300/1400-24,25	1942	76.5	9.0	0.35	232	9.1
1400/1600R24,25	1942	76.5	9.0	0.35	260	10.2
1600-24,25	1916	75.4	9.0	0.35	293	11.5
155A1800-24,25	1926	75.8	6.0	0.24	340	13.4
235-25	1934	76.1	9.0	0.35	560	22.1
265-25	2010	79.1	12.0	0.47	570	22.4
2100R33	2553	100.5	9.0	0.35	413	16.3

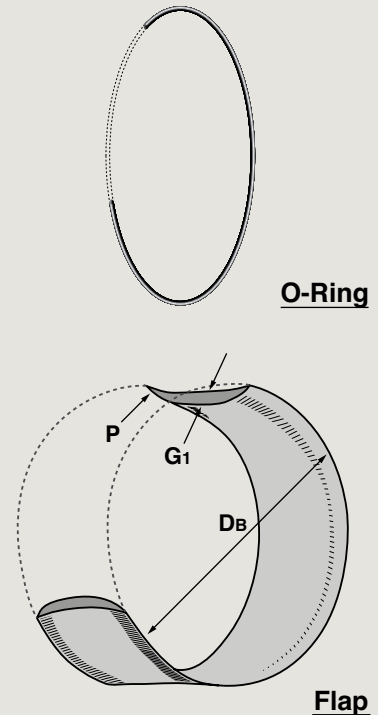

NOTES

A large white rectangular area with horizontal dotted lines, intended for writing notes. The lines are evenly spaced and extend across the width of the page.

Firestone

200 4th Avenue S
Nashville, TN 37214

CUSTOMER SERVICE
800.572.8905

OTRCUSTOMERSERVICE@BFUSA.COM

